

LOADER DIRECTIONAL CONTROL VALVE

“LV”

LV22RFSTKLB

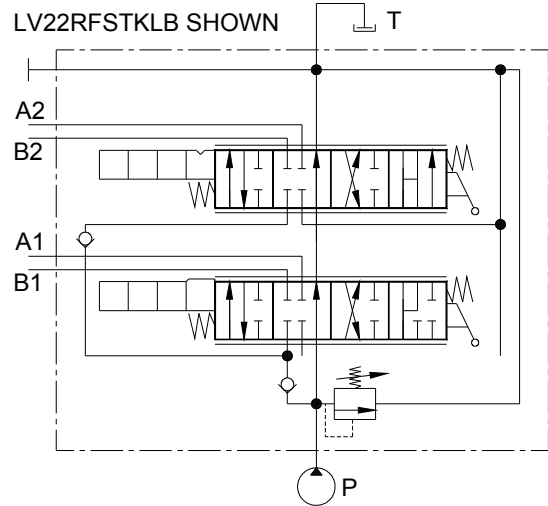

LV22RFSTKABW



FEATURES:

- O’RING PORTS to eliminate leakage.
- FOURTH POSITION REGEN allows cylinder to rapidly extend.
- POWER BEYOND CAPABILITY to fit your multi valve circuits.
- PRECISION GROUND IOSSO PLATED SPOOLS that assure long life.
- INDIVIDUAL DROP LOAD CHECKS prevent the load from dropping when the spool is shifted.
- FOURTH POSITION FLOAT allows spool movement to a fourth position and makes all ports common to each other (last spool only).

SPECIFICATIONS:

- 10 gpm (38 lpm) Nominal Capacity.
- Rated up to 4000 psi (275 bar).
- Port Sizes-Inlet/Outlet #8SAE (3/4-16).
-Work Ports #8SAE (3/4-16).
- 25 Micron Filtration Recommended.
- Weight -LV22 = 10.9 lbs. (4.9 kg).

MATERIALS:

- Cast Iron Body
- Buna N O’Rings
- IOSSO Plated Steel Spools
- Black Nylon Ball Knob

LV – GENERAL INFORMATION

The Brand LV22, loader directional control valve, is a superbly designed two spool monoblock valve suitable for Front End Loaders. The LV22 offers two parallel, tandem center 4-way work sections available with two of the following spool actions: float, regenerative or spring-to-center. The valve is also field convertible to closed center or power beyond with the appropriate cartridge.

SPOOLS – Tandem center 4-way (T, in model code) powers a cylinder or a motor in both directions. Regen 4-way (R, in model code) acts just like a Tandem center spool in the standard three positions, but also has a fourth position that allows for rapid extension of a cylinder (uses FS spool action). For more information, see the Spool Schematics below.

SPOOL ACTIONS – Spring-to-center (S, in model code) returns the handle to neutral when the handle is released. Fourth position spring centering (FS, in model code) is similar to spring-to-center except it has a fourth position that allows a cylinder to rapidly extend (must use Regen spool). Fourth position float (K, in model code) is similar to spring-to-center except it has a fourth position detent that makes all ports common to each other (used with tandem center spool only).

ACTUATORS – Standard joystick handle (A, in model code) is used to actuate two adjacent spools with one handle. Optional joystick handles (A1, A2 & A3, in model code) also actuate two adjacent spools with one handle, but have different actuation patterns (See joystick diagram on page four). Enclosed lever handle (L, in model code) pressurizes the “B” port when the handle is pushed towards the valve body and is convertible from the vertical to the horizontal position. No actuator (N, in model code) is used when it is necessary to connect the spool to an external actuator.

OPTIONS – Power beyond (W, in model code) offers high pressure carryover for valves downstream. The LV22 valve is also field convertible to power beyond with the LV2-W power beyond cartridge kit. Closed center (C, in model code) blocks the neutral flow path and is required in pressure compensating, i.e. closed center systems. The LV22 valve is also field convertible to closed center with the LV2-C closed center cartridge kit. Adjustable relief (B, in model code) is factory preset at 2000psi (138 bar), but is adjustable from 1200 to 3100 psi (83 to 214 bar) and can be ordered in pressure intervals of 100 psi (6.9 bar). For pressure setting above the standard range, use spring P/N S064 for relief settings of 3100psi to 4000psi (214 to 276 bar). For pressure setting below the standard range, use spring P/N S065 for relief settings of 500psi to 1200psi (34 to 83 bar).

LV – EXAMPLES OF COMMON MODEL CODES:

LV22RFSTKABW..... Two spool valve, tandem center fourth position regen spool (R), fourth position spring center (FS), tandem center (T), fourth position float (K), joystick assembly (A), adjustable relief (B) 2000 psi (138 bar) setting and power beyond (W).

LV22TSTKLB..... Two spool valve, tandem center (T), spring centering (S), tandem center (T), fourth position float (K), enclosed handle assembly (L) and adjustable relief (B) 2000 psi (138 bar) setting.

LV – COMPLETE LIST OF OPTIONS AND ACCESSORIES:

LV2-C..... Closed center cartridge kit.
LV2-FS..... Fourth position spring centering (Use with Regen spool)
LV2-HA..... A and A1-style joystick kit (Operates two spools simultaneously)
LV2-HA2..... A2 and A3-style joystick kit (Operates two spools simultaneously)
LV2-HL..... L-style enclosed handle kit (Operates one spool only).
LV2-K..... Fourth position float (Use with Tandem spool).
LV2-S..... Spring centering kit.
LV2-SK..... Seal kit for spool, relief, load checks and cartridge.
LV2-W..... Power beyond cartridge kit.

LV – CREATING A MODEL CODE FOR LV'S:

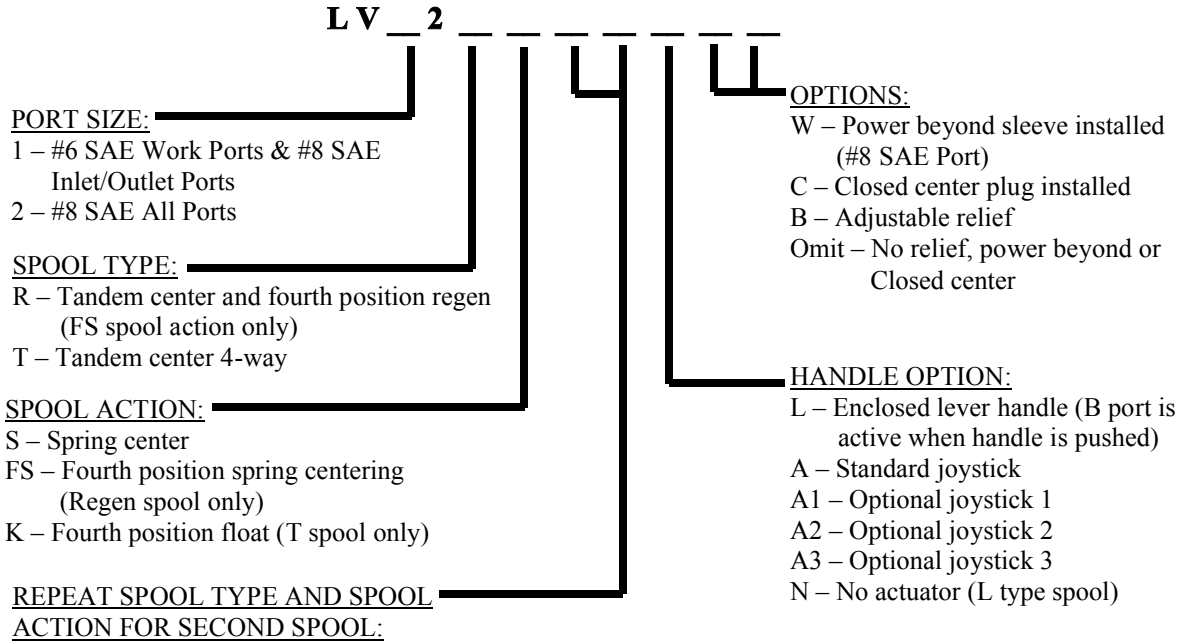

LV – SPOOL SCHEMATICS:

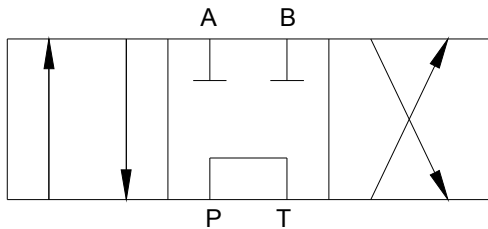

Tandem Center (T) - Powers cylinder or motor in both directions. Pump unloads to tank when spool is in neutral. Cylinder or motor blocked when spool in neutral.

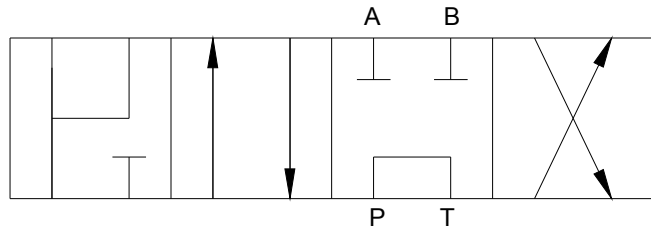

Regen (R) - Same as Tandem spool in standard three positions. Fourth position allows for rapid extension of cylinder.

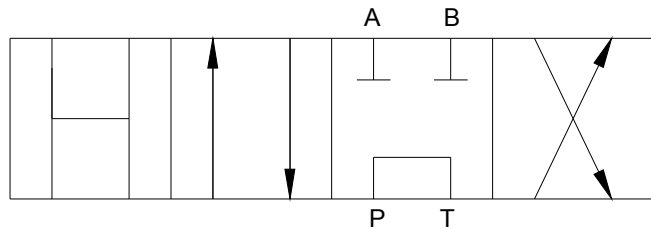

Float (K) - Same as Tandem spool in standard three positions. Detented Fourth position allows cylinder to move or motor to rotate when spool is detented.

LV – JOYSTICK MOVEMENT SCHEMES:

LV22RFSTKAB

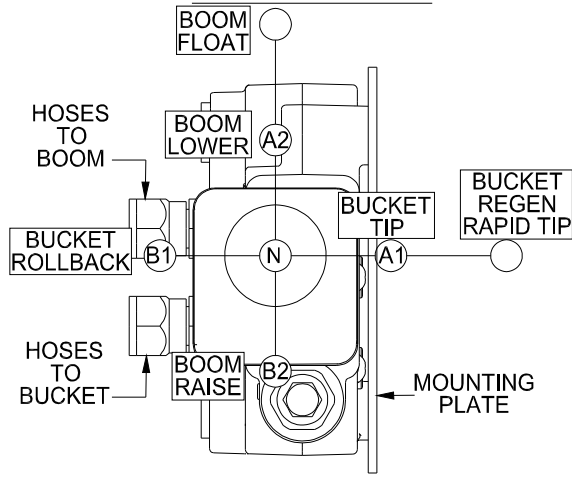

LV22TKRFS1B

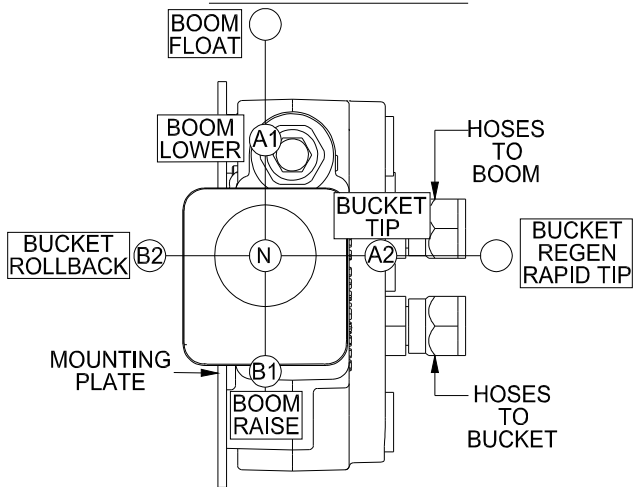

LV22RFSTKA2B

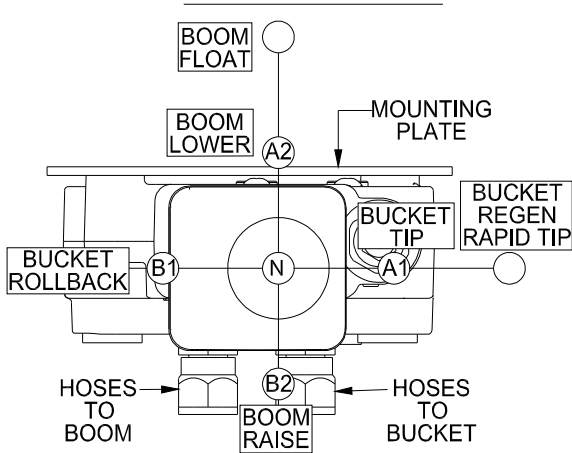

LV22TKRFS3B

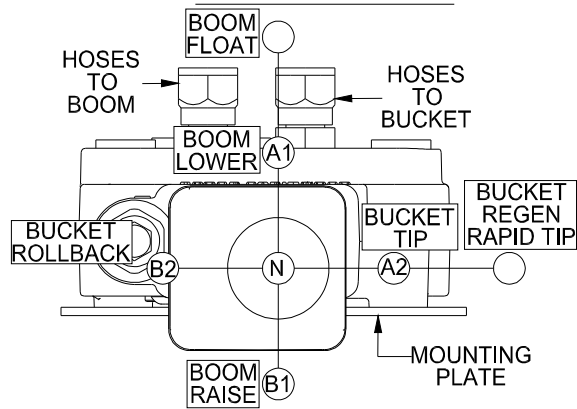

LV – FLOW AND PRESSURE INFO:

Neutral Flow Pressure Drop

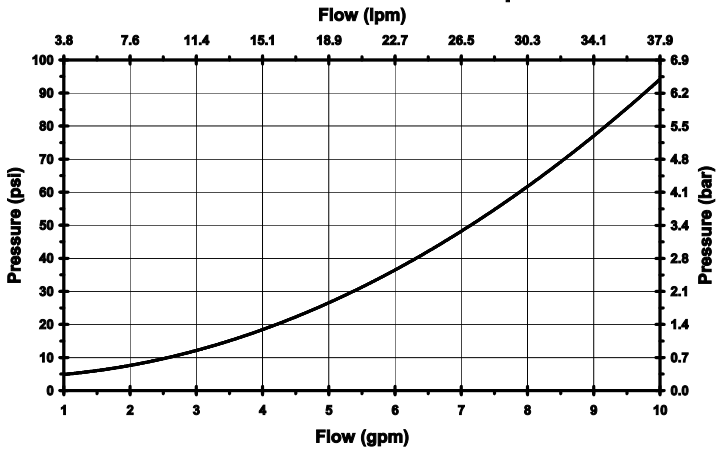

Pressure Drop vs. Flow for P to A or B

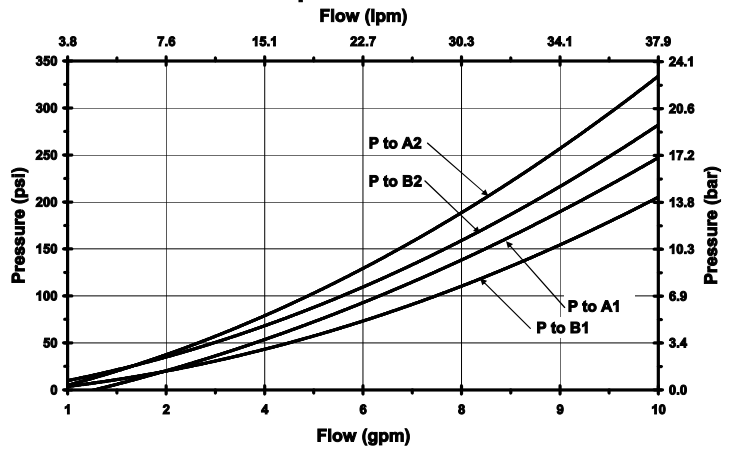

Pressure Drop vs. Flow for A or B-T

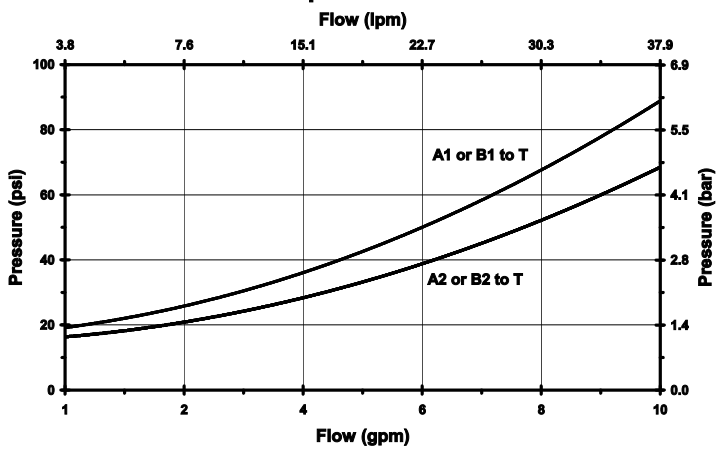

Pressure vs. Flow for LV Relief

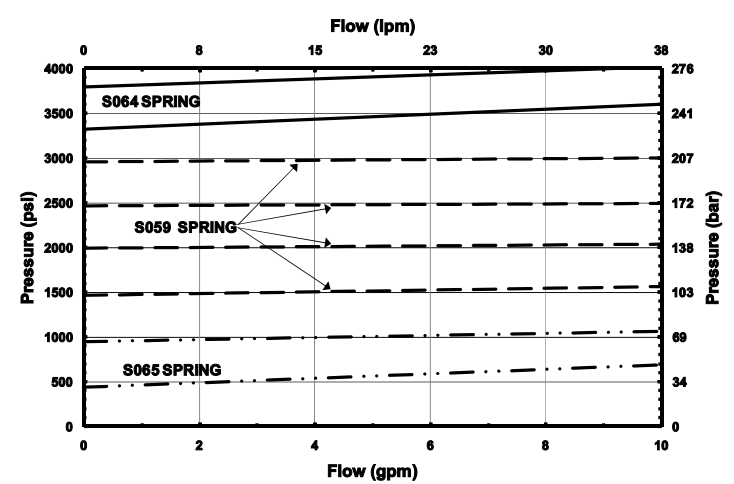

DIMENSIONAL DATA: inches & [millimeters]

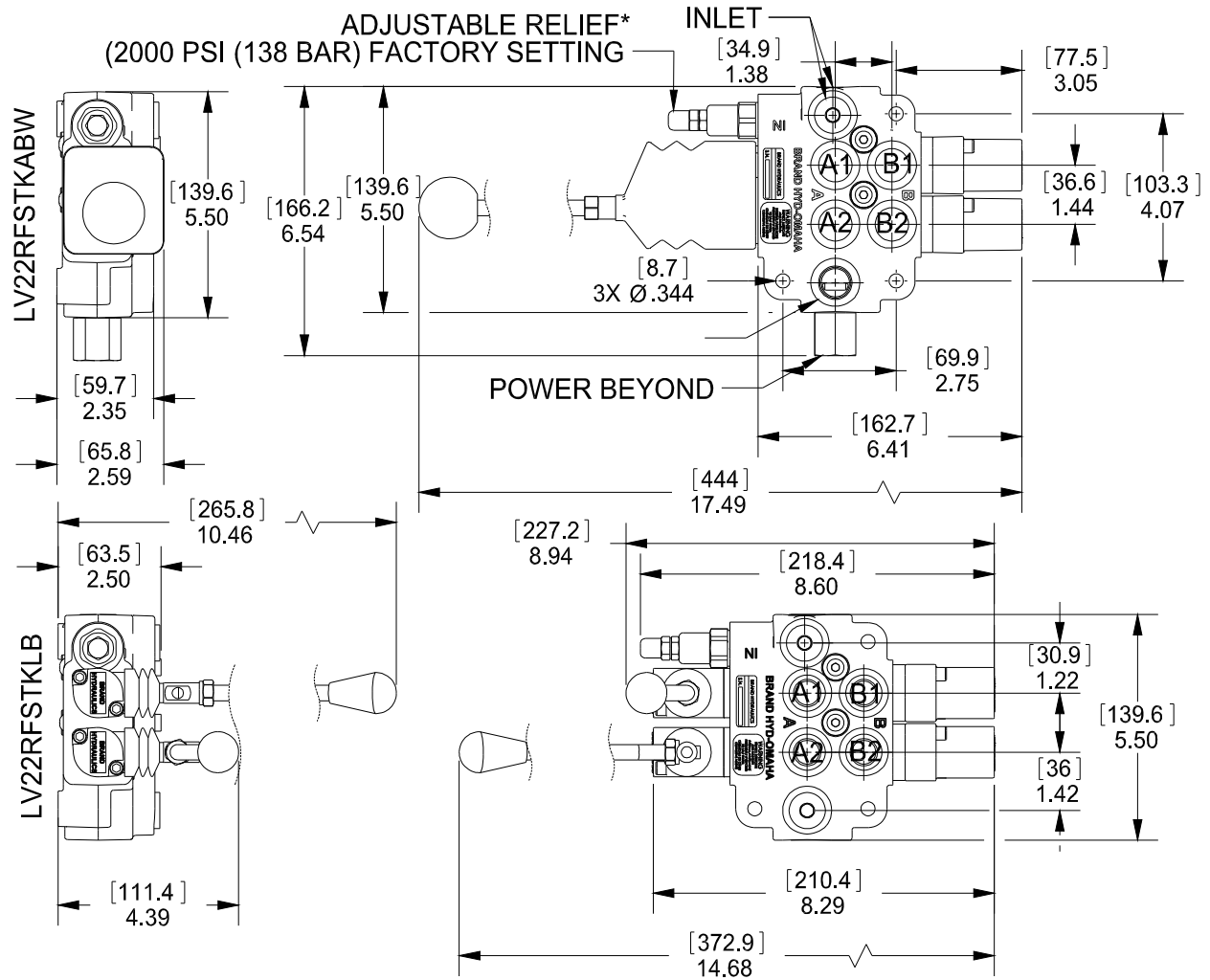

*FIELD ADJUSTABLE FROM 1200 TO 3100 PSI (83-214 BAR).