

## INSTALLATION SHEET FOR BX50 STYLE PROPORTIONAL DIVIDER KEEP WITH PRODUCT UNTIL INSTALLED

ADDITIONAL SHEETS MAY BE PRINTED OUT FROM OUR WEBSITE [WWW.BRAND-HYD.COM](http://WWW.BRAND-HYD.COM) UNDER PRODUCT CATALOG SECTION

Mounting Surface – The valve must be mounted on a flat surface. It is important not to bend or twist the casting when mounting because this may cause the comp spool to bind. On rigid surfaces we recommend washers between casting and mounting surface.

What happens when I block one outlet port? – The compensation spool will try to open more flow to the blocked port. This in turn will block off flow to the other port.

Pipe thread sealant – Warranty is void when Teflon tape is used to seal pipe threads. This is because Teflon tape is a friction reducing agent which allows customers to over-torque fittings. We recommend using a sealant that does not include friction reducing agents i.e. Lead Plate.

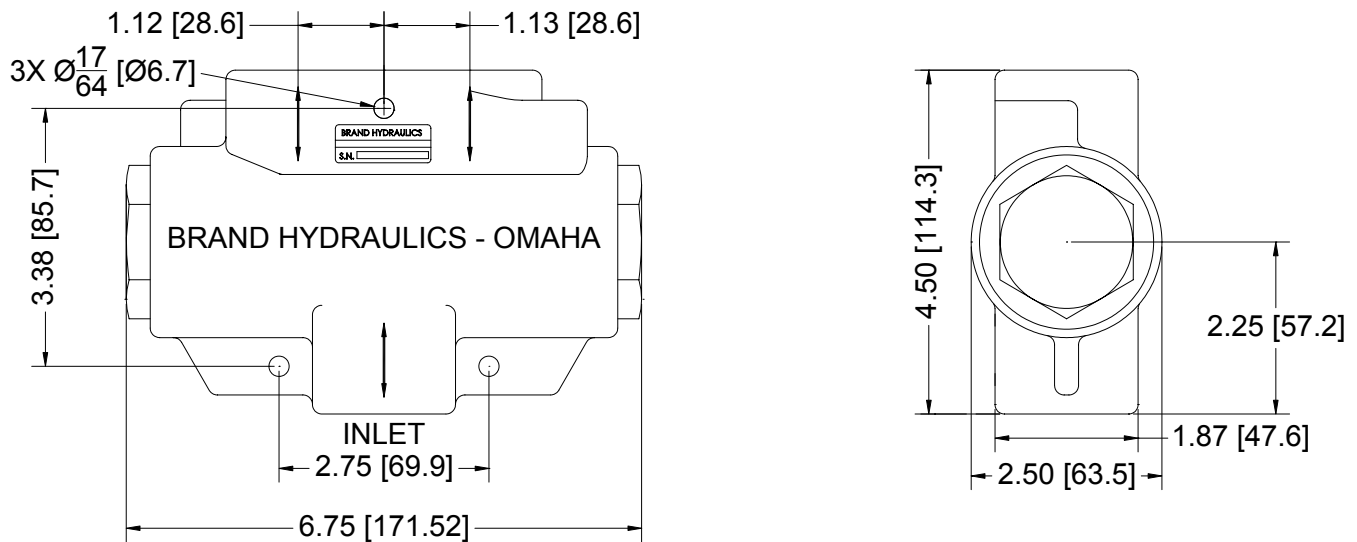

**Figure 1: Dimensional Data for BX50-16SAE valves in inches & [millimeters].**