

## 4 – WAY DIRECTIONAL CONTROL VALVE WITH OR WITHOUT FLOW CONTROL “DC SERIES”

DCF16TM304LS

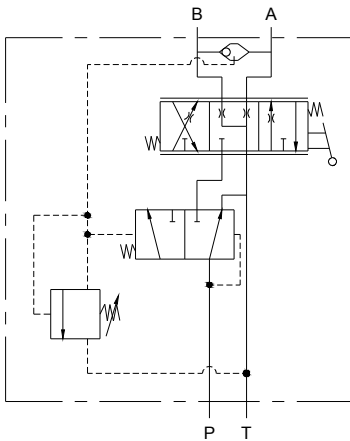

DC7504LS

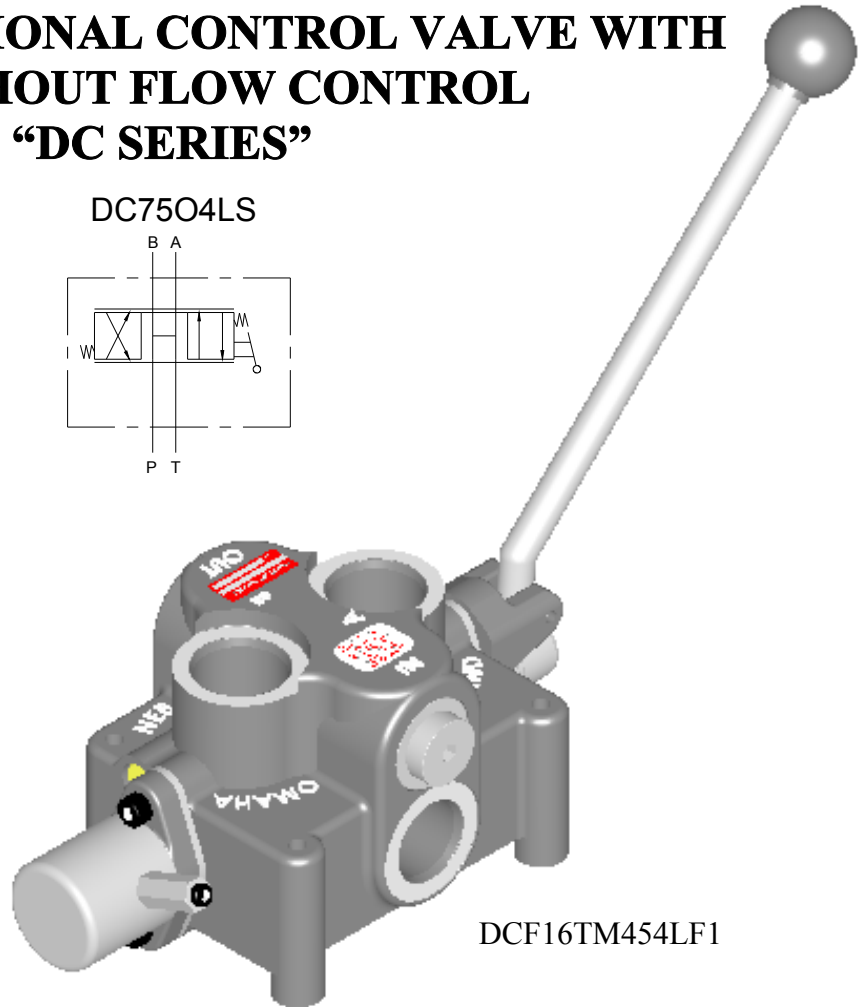
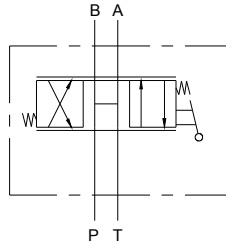

DCF16TM454LF1

### **FEATURES:**

- **PILOT OPERATED RELIEF VALVE** is standard on every DCF valve.
- **FULL RANGE PRESSURE COMPENSATED** by-pass type flow control valve (DCF valve).
- **DCF REDUCES** the number of fittings, plumbing and potential leaks in hydraulic circuits.
- **FINE POSITIVE METERING** in either direction with the manual handle (DCF valve).
- **PRECISION GROUND IOSSO PLATED SPOOL** that assures long life (DC & DCF valves).
- **OPTIONAL VENT PORT** to unload relief (DCF only).
- **OPTIONAL PILOT OPERATED ACTUATOR** for remote operation (DC & DCF valves).
- **OPTIONAL O’RING PORTS** to eliminate leakage (DC & DCF valves).

### **SPECIFICATIONS:**

- **Rated for 0-45 gpm (0-170 lpm).**
- **Rated for 3000 psi (207 bar).**
- **Std. port sizes (Consult factory for others).**
  - 3/4” NPT all ports.
  - #16 SAE (1-5/16-12) all ports.
- **Weights 16 lbs. (7.3 kg).**
- **20 – Micron filtration recommended.**

### **MATERIALS:**

- **Cast Iron Body**
- **Buna N O’Rings**
- **IOSSO Plated Steel Spool**
- **Consult Factory for Stainless Steel Spools**
- **High Strength Cast Iron Body (DCF 16SAE only)**

## DC SERIES – GENERAL INFORMATION:

The Brand, DCF directional flow control valve combines the features of a four-way directional control valve, a full range pressure compensated by-pass type flow control valve, and a pilot operated pressure relief valve, all in one compact package. This valve reduces the number of fittings, plumbing and potential leakage points in hydraulic circuits. The manual handle provides fine metering to either port. Flow to the work port is directly proportional to the movement of the lever. Flow out of each work port is constant regardless of load changes, this allows the customer to maintain smooth and constant movement of a cylinder or motor. Every DCF comes standard with a pilot operated relief. The tank port must be plumbed directly back to tank.

The Brand, DC directional control valve does not have the flow control feature of the DCF. The DC can be used in series but the spool is difficult to shift when there is tank pressure. The DC offers an optional high lift ball spring relief to take the place of the standard pilot operated relief on the DCF. The manual handle provides metering to either port.

**SPOOL TYPE** – The spool types we offer are tandem center 4-way (T), open center 4-way (O), closed center 4-way(C), fine metering 4-way (M), tandem metering 4-way (TM), and tandem center 3-way (T3). (See chart on next page and schematics on page #4 for information on spool types)

**ACTUATORS** – Lever handle (L) pressurizes the B port when the handle is pushed towards the valve body. Pilot operated (P) is used when it is necessary to remotely operate the valve. Rotary handle (H) is used to rotate spool in or out of valve body. No actuator (N) L type spool.

**SPOOL ATTACHMENTS** – Three-position detent (D) holds the spool in neutral and both active positions. Friction detent (F1) applies friction to the spool so that the spool does not move when the handle is released from either side of neutral, a detent groove clearly indicates neutral position. Spring center (S) returns the handle to neutral when the handle is released. Two-position detent (2D) P to B only. Two-position detent (D2) P to A only. Rotary friction detent (E) applies friction to the spool as it is rotated so that the spool does not rotate when the handle is released either side of neutral, a detent groove clearly indicates neutral position. Adjustable spool stop handle (AH) allows the customer to stop the spool at any position in one direction only. High lift ball spring relief (B) provides relief for DC only. Vent port (V) allows relief to unload (DCF only). Top port (TP) allows the customer to plumb the inlet, outlet on the same surface as the work ports (DC only).

## DC SERIES – EXAMPLES OF COMMON MODEL CODES:

**DC16T4LBS**.....Four-way directional valve, #16 SAE port size, tandem center four-way spool, L style actuator, high lift ball spring relief and spring center.  
**DC75O4LBD**.....Four-way directional valve, 3/4" NPT port size, open center four-way spool, L style actuator, high lift ball spring relief and three-position detent.  
**DCF16TM304LF1**.....Four-way directional flow control, #16 SAE port size, tandem metering spool, 0-30 gpm (0-113 lpm) metering capability, four-way, L style actuator and friction detent.  
**DCF75M154LS**.....Four-way directional flow control, 3/4" NPT port size, fine metering spool, 0-15 gpm (0-57 lpm) metering capability, four-way, L style actuator and spring center.

## DC SERIES – COMPLETE LIST OF OPTIONS AND ACCESSORIES:

**DC-D**.....Three-position detent kit for DC and DCF.  
**DC-D2**.....Two-position detent kit for DC and DCF.  
**DC-AH**.....Spool stop for front of valve.  
**DC-AA**.....Spool stop for front and rear of valve.  
**DC-A**.....Spool stop for rear of valve (No other attachments may be used with this kit).  
**DC-HL**.....Handle kit for DC and DCF.

## DC SERIES – COMPLETE LIST OF OPTIONS AND ACCESSORIES CONT...

- DC-K**..... Seal kit for DC.
- DC-KU**..... Seal kit for DC with urethane polypac seal.
- DC-S**..... Spring centering kit for DC and DCF.
- DCF-F1**..... Neutral position friction detent for DC and DCF.
- DCF-K**..... Seal kit for DCF.
- DCP-K**..... Seal kit for pilot operated DC.
- DCF-CART-N**..... Pilot operated pressure relief valve for DCF.
- TS-B**..... High lift ball spring relief for DC.

## DC SERIES – CREATING A MODEL CODE FOR DC'S:

<p><b>SERIES:</b></p> <p>DC – 4-way directional control valve DCF – 4-way directional control valve with flow control</p> <p><b>PORT SIZE:</b></p> <p>75 – 3/4" inlet/outlet and work ports 16 – #16SAE inlet/outlet and work ports</p> <p><b>SPOOL TYPE:</b></p> <p>T3 – Tandem center 3-way (DC only) (Omit 4) C – Closed center (DC only) T – Tandem center (DC only) O – Open center (DC only) M – Fine metering TM – Tandem metering</p> <p><b>FLOW SETTING:</b></p> <p>Omit – When using T and O spool 15 – 0-15 gpm (0-57 lpm) M and TM only 30 – 0-30 gpm (0-113 lpm) M and TM only 45 – 0-45 gpm (0-170 lpm) M and TM only</p>	<p><b>SPOOL ATTACHMENTS:</b></p> <p>S – Spring center D – Three-position detent F1 – Ball friction detent AH – Adjustable spool stop handle end B – High lift ball spring relief for DC (TS-B) R – Pilot relief (Std. on DCF) V – Vent port on relief (DCF only) TP – Top ported (DC only) 2D – Two-position detent (P to B only) D2 – Two position detent (P to A only) E – Rotary ball friction detent</p> <p><b>ACTUATORS:</b></p> <p>L – Lever handle (B port is active when handle is pushed) P – Pilot operated (500 psi (34.5 bar) max. pilot pressure) N – No actuator (L type spool) H – Rotary handle (Used in conjunction with rotary ball friction detent (E))</p> <p><b>3-WAY OR 4-WAY:</b></p> <p>3 – 3-way (Tandem spool and DC only) 4 – 4-way</p>
---	--

## DC SERIES – FLOW AND PRESSURE INFO:

**Pressure vs. Flow for Pilot Relief (DCF)**

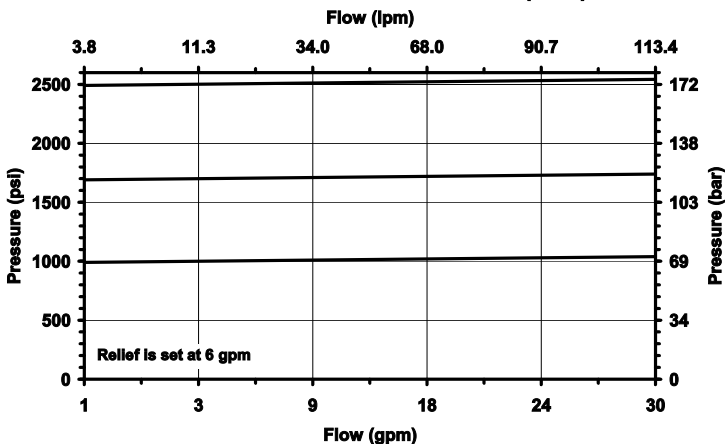

**Pressure vs. Flow for B Relief (DC)**

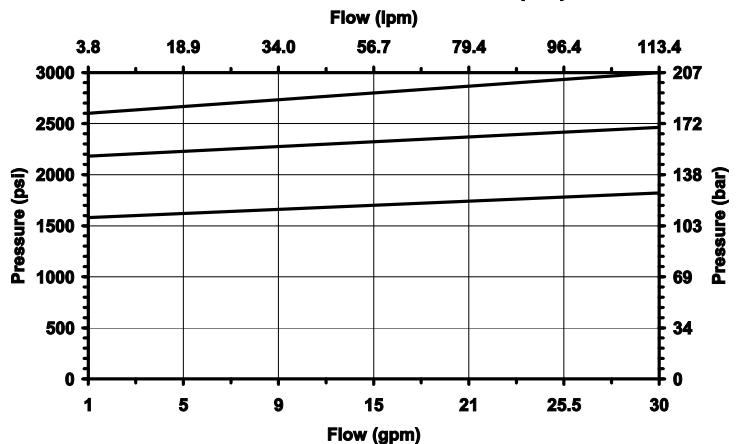

### DC SERIES – FLOW AND PRESSURE INFO CONT...

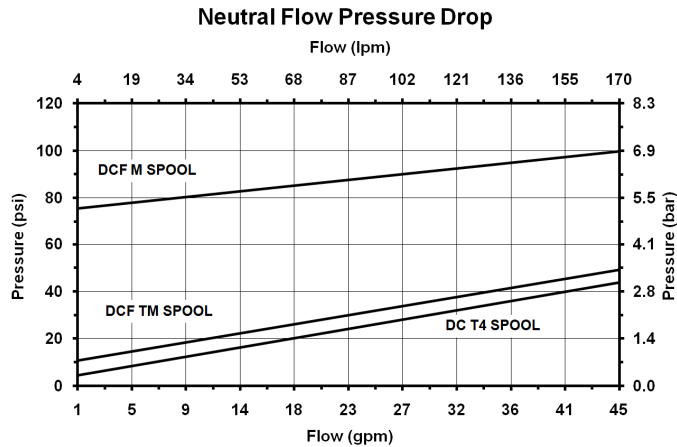

### SPOOL SCHEMATICS:

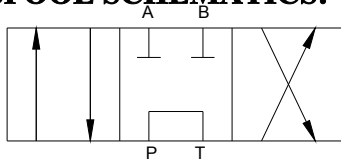

**Tandem Center (T)** - Powers cylinder or motor in both directions (metering capability is very limited). Pump unloads to tank when spool is in neutral. Cylinder or motor blocked when spool in neutral. This spool is not designed for DCF valve.

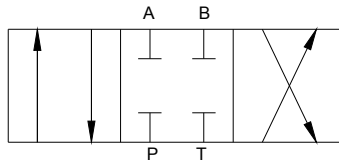

**Closed Center (C)** - All ports are blocked in neutral. Blocks cylinder or motor in neutral. Required for use with pressure compensated pump. This is not available for DCF valve.

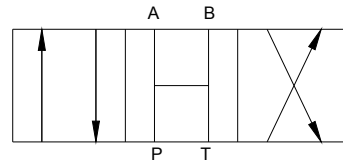

**Open Center (O)** - All of the ports are connected to tank when the spool is in neutral. Allows cylinder to move or motor to rotate when spool is in neutral. This spool is not designed for DCF valve.

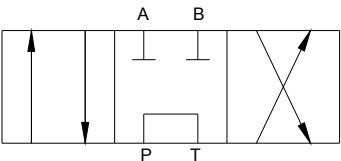

**Tandem Metering Spool (TM)** - Similar to (T) spool except much finer metering control. The pressure drop in neutral is lower than the (M) spool. Cylinder or motor blocked in neutral and pump unloads to tank. This spool is designed for DCF valve.

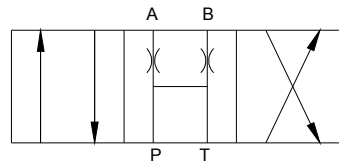

**Fine Metering Spool (M)** - The pressure drop in neutral is higher than the (TM) spool. Requires external locking valves to hold cylinder, because ports A and B are open (orificed) in the neutral position. Extremely fine metering control. This spool is designed for the DCF valve and acts as closed center in DC valve.

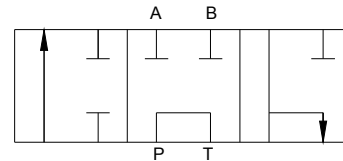

**Tandem Three Way (T3)** - Powers the cylinder in one direction. Pump unloads to tank when spool is in neutral, or when spool is being reversed. Cylinder is blocked when spool is in neutral. Port "B" is plugged. This spool is designed for the DC valve.

### DIMENSIONAL DATA (DCF16TM454LS SHOWN): inches & [millimeters]

