

## HIGH VOLUME NON-ADJUSTABLE PROPORTIONAL FLOW DIVIDERS

“B”

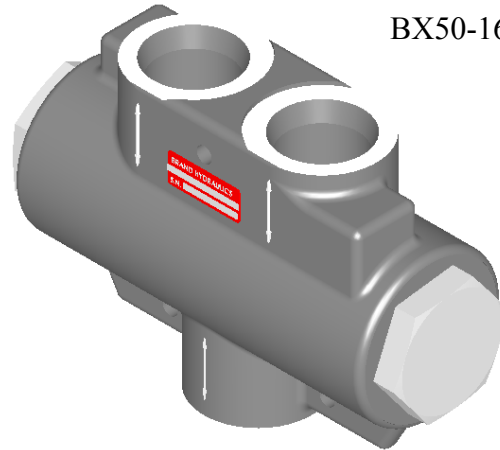

BX50-16SAE

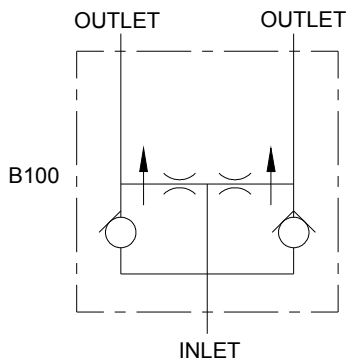
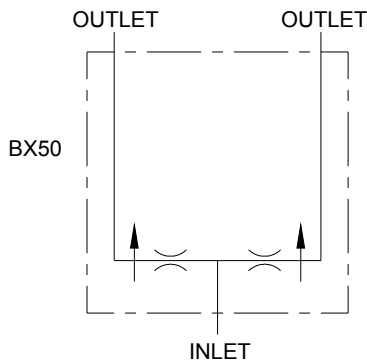
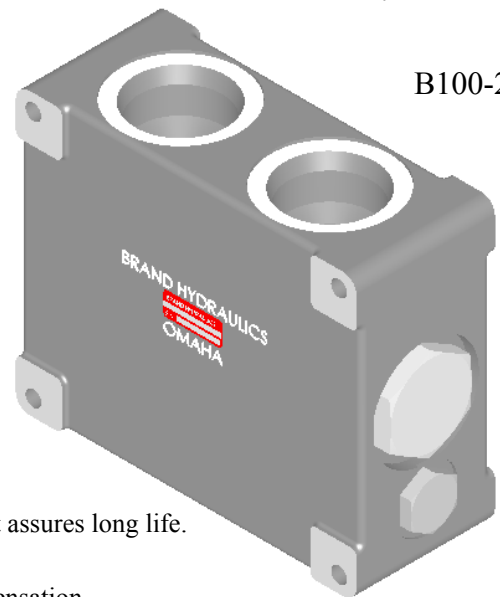

B100-24SAE

### FEATURES:

- **PRECISION GROUND HEAT TREATED SPOOL** that assures long life.
- **PRESSURE COMPENSATION** for both outlets.
- **EVERY B IS TESTED** for flow ratio and pressure compensation.
- **DIVIDES INLET FLOW INTO TWO FLOWS** of equal flow or a ratio up to 85:15.
- **OPTIONAL FREE REVERSE FLOW (B100)** allows fluid to move from the outlet ports to the inlet port.

### SPECIFICATIONS:

- **Rated for 3000 psi (207 bar).**
- **BX50 is rated for 25-45 gpm (94-170 lpm).**
- **B100 is rated for 30-120 gpm (113-454 lpm).**
- **30-Micron filtration recommended.**
- **Weight - BX50 = 9 lbs. (4.1 kg).**  
- B100 = 26 lbs. (11.8 kg).
- **Standard port sizes.**
  - #24SAE (1-7/8-12) all ports (B100).
  - #16SAE (1-5/16-12) all ports (BX50).

### MATERIALS:

- **High Strength Cast Iron Body (BX50)**
- **Cast Iron Body (B100)**
- **Buna N O'Rings**
- **Heat Treated Steel Spool**
- **Delrin Free Reverse Check Seat**

## B – GENERAL INFORMATION:

The Brand, non-adjustable, proportional flow divider comes in two basic models BX50, and B100. The B series receives a single stream of fluid and divides it into two output streams. The ratio of division to the two outlets will remain constant even though the work being done by one of the streams is much greater than the work being done by the other. The ratio of the outlet flows, remains constant even when the input flow increases or decreases. The ratio of the outlet flows may be varied from equal flow (50:50) all the way up to an 85:15 ratio.

**BX50-16SAE** – is a non-adjustable divider that receives a single stream and divides into two streams. The two outlet flows are pressure compensating and the sum of said flows equals the inlet flow. The ratio of the outlet flows must be specified when ordering.

**B100-24SAE** – is very similar to the BX50 in that it is a non-adjustable proportional divider, but in addition to the BX50 it also offers free reverse flow for both outlet ports. Flow can travel in reverse through both outlet ports and is not metered when it goes in reverse. The non-metered flow travels past the orificed spool, through the delrin checks, and through the inlet. The two outlet flows are pressure compensating and the sum of said flows equals the inlet flow. The ratio of the outlet flows must be specified when ordering.

## B – EXAMPLES OF COMMON MODEL CODES:

- BX50-16SAE**..... #16SAE all ports, and divides at 50:50 ratio.
- BX50-16SAE(60:40)**..... #16SAE all ports, and divides at 60:40 ratio.
- BX50-16SAE( : )**..... #16SAE all ports, and specify division ratio in parenthesis.
- B100-24SAE**..... #24SAE all ports, 75 to 120 gpm (284 to 454 lpm) flow rating, free reverse flow, and divides at 50:50 ratio .
- B100-24SAE-380**..... #24SAE all ports, 45 to 75 gpm (170 to 284 lpm) flow rating, free reverse flow, and divides at 50:50 ratio .
- B100-24SAE-316**..... #24SAE all ports, 30 to 55 gpm (113 to 208 lpm) flow rating, free reverse flow, and divides at 50:50 ratio .
- B100-24SAE(60:40)**..... #24SAE all ports, free reverse flow, and divides at 60:40 ratio.

## B – FLOW AND PRESSURE INFO:

**Pressure Drop vs. Flow for BX50**

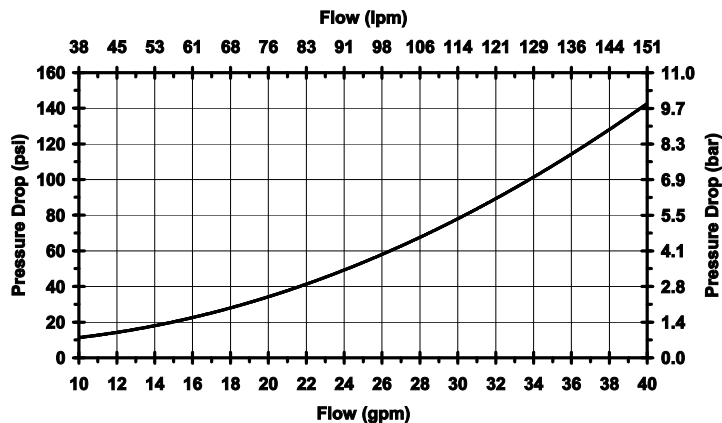

**DIMENSIONAL DATA: inches & [millimeters]**

B100-24SAE

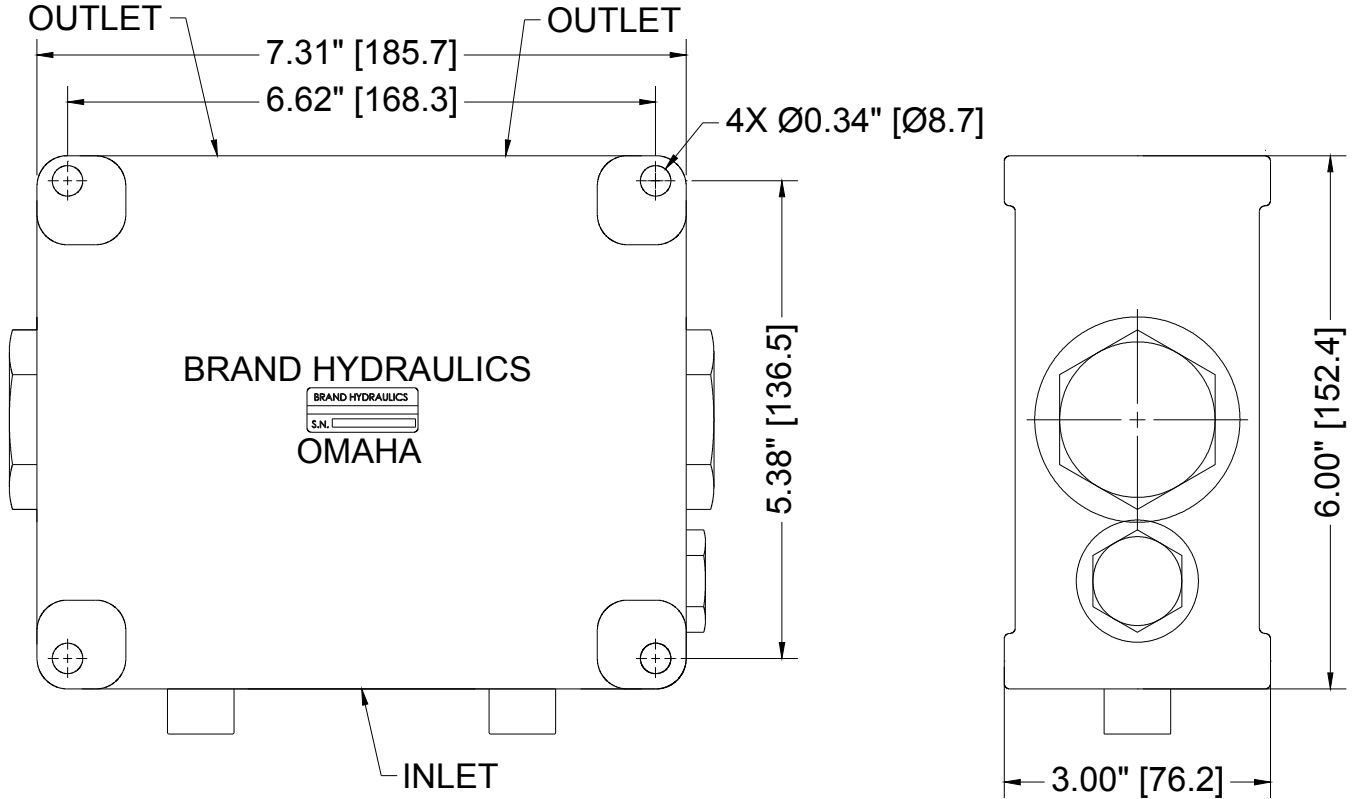

BX50-16SAE

