

MONO BLOCK DIRECTIONAL CONTROL VALVE

TS1120TSLB

“TS”

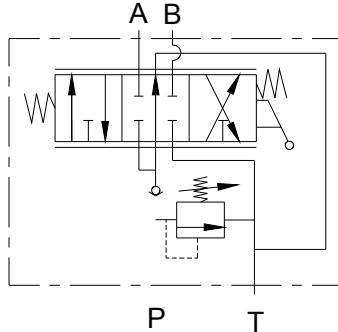

TS2120TSTF1JB

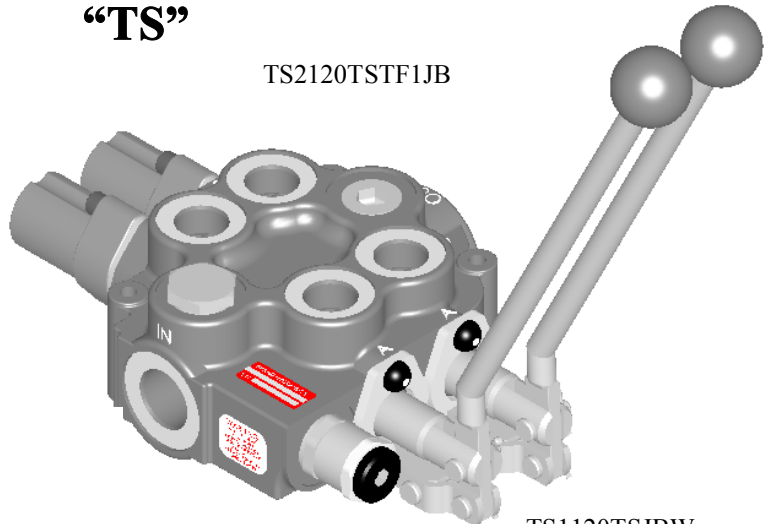

TS3120TSDTSTKJB

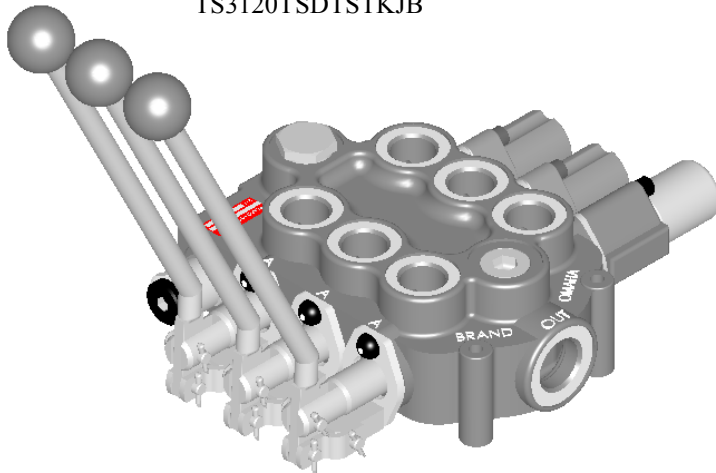

TS1120TSJBW

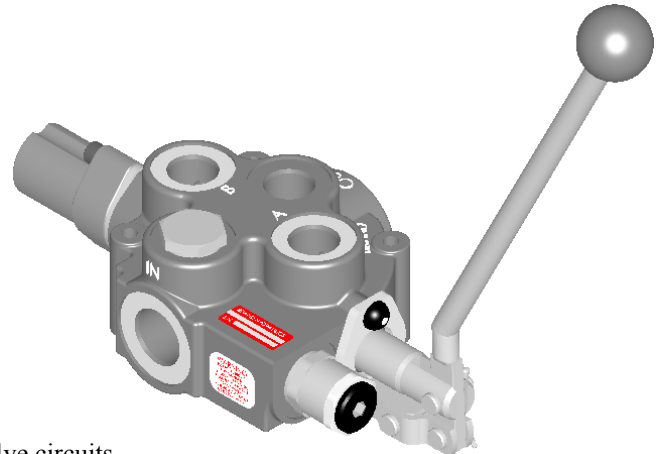

FEATURES:

- **O’RING PORTS** to eliminate leakage.
- **POWER BEYOND CAPABILITY** to fit your multi valve circuits.
- **BUILT IN ANTI-DROP CHECK** prevents the load from dropping when the spool is shifted.
- **FOURTH POSITION FLOAT** allows spool movement to a fourth position and makes all ports common to each other (last spool only).
- **PRECISION GROUND IOSSO PLATED SPOOL** that assures long life.

SPECIFICATIONS:

- **18 gpm (68.0 lpm) Nominal Capacity.**
- **Rated up to 3000 psi (207 bar).**
- **Port Sizes-Inlet/Outlet #12SAE (1-1/16-12).**
 -Work Ports #10SAE (7/8-14).
- **10 Micron Filtration Recommended.**
- **Weight** -TS1 = 9 lbs. (4.1 kg).
 -TS2 = 14 lbs. (6.4 kg).
 -TS3 = 20 lbs. (9.1 kg).

MATERIALS:

- **Cast Iron Body**
- **Buna N O’Rings**
- **IOSSO Plated Steel Spools**
- **Black Nylon Ball Knob**

TS – GENERAL INFORMATION

The Brand, mono block directional control valve is available in one (TS1), two (TS2) and three (TS3) spool configurations. This valve was designed for applications in which one valve is required to operate separate circuits independently. The TS offers parallel, tandem center 4-way, open center 4-way (motor spool), and tandem 3-way spools. The valve is also field convertible to closed center and power beyond.

SPOOLS – The tandem three-way (T3) powers a cylinder in one direction. Tandem center 4-way (T) powers a cylinder or a motor in both directions. Closed center 4-way (C) blocks all ports in neutral and must be used with a pressure compensated pump. Open center 4-way (O) connects all ports to tank when in neutral.

SPOOL ACTION – Three position detent (D) holds the spool in neutral and both active positions. Rotary friction detent (E) applies friction to the spool as it is rotated so that the handle does not rotate when the handle is released, a detent groove clearly indicates neutral position (only available on TS1). Friction detent (F1) applies friction to the spool so that the spool does not move when the handle is released, a detent groove clearly indicates neutral position. Spring center (S) returns the handle to neutral when the handle is released. Spring center detent (SD) springs back to neutral from one position and is mechanically detented in the other position. Spring center hydraulic detent (SH) springs back to neutral from P to B position and pressure release detent in the other direction when the cylinder completes its return stroke (P to A in detent and 800-1000 psi (55 to 69 bar) kick-out). Fourth position float (K) is similar to spring center except it has a fourth position that makes all ports common to each other (last spool section only). Normally open electric switch (WO) is used with (S), (F1) and (D) options. Normally closed electric switch (WC) is used with (S), (F1) and (D) options. The electric switches can be used on the TS1, TS2 and TS3 (first and third spool only).

ACTUATORS – Lever handle (L) pressurizes the B port when the handle is pushed towards the valve body. Lever handle (J) pressurizes the A port when the handle is pushed towards the valve body. Rotary handle (H) is used to rotate spool in or out. No actuator (N) is used when it is necessary to connect the spool to an external actuator (L type spool). No actuator (M) is used when it is necessary to connect the spool to an external actuator (J type spool).

OPTIONS – Power beyond (W) offers high pressure carryover for valves down stream. The TS series is also field convertible to power beyond. Area differential relief cartridge (B) is available in pressure intervals of 100 psi (6.9 bar).

GENERAL CONVERSION INFORMATION

NOTE: The standard 1, 2 and 3 spool castings with (O) or (T) spools are assembled at the factory with the TS315 plug in the 10SAE (7/8-14) (1) top port.

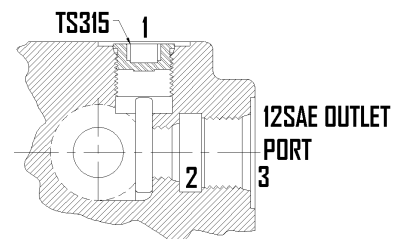

CLOSED CENTER CONVERSION – To have the casting in closed center operation, both the top port (1) and internal port (2) must be plugged. Take the TS315 plug from the top port (1) and insert it into the internal port (2). Then plug the top port (1) with any std. SAE plug (7/8 – 14) or purchase a plug from the factory. Closed center blocks “Pump” only, the condition of ports A and B depend on the spool type. (See illustration above)

POWER BEYOND CONVERSION – To convert the valve to power beyond operation, take the TS315 plug from the top port (1) and insert it into the internal port (2). Next, plumb a #10 SAE fitting from the top port (1) to the adjoining valve. Lastly, run a line from the #12 SAE outlet port (3) to the reservoir. (See illustration above)

TS – EXAMPLES OF COMMON MODEL CODES:

- TS1120TSJBW**..... Single spool valve, tandem center 4-way spool (T), spring center (S), lever handle (J), area-diff. relief cartridge (B) and power beyond (W).
- TS2120TDTSJB**..... Two spool valve, the first section has a tandem center 4-way spool (T) with three position detent (D), the second section has a tandem center 4-way spool (T) with spring center (S), lever handles (J), and area-diff. relief cartridge (B).
- TS3120TSTSTKJ**..... Three spool valve, the first and second sections have a tandem center 4-way spools (T) with spring center (S), the third section has a tandem center 4-way spool (T) with fourth position float (K) and lever handles (J).

TS – CREATING A MODEL CODE FOR TS'S:

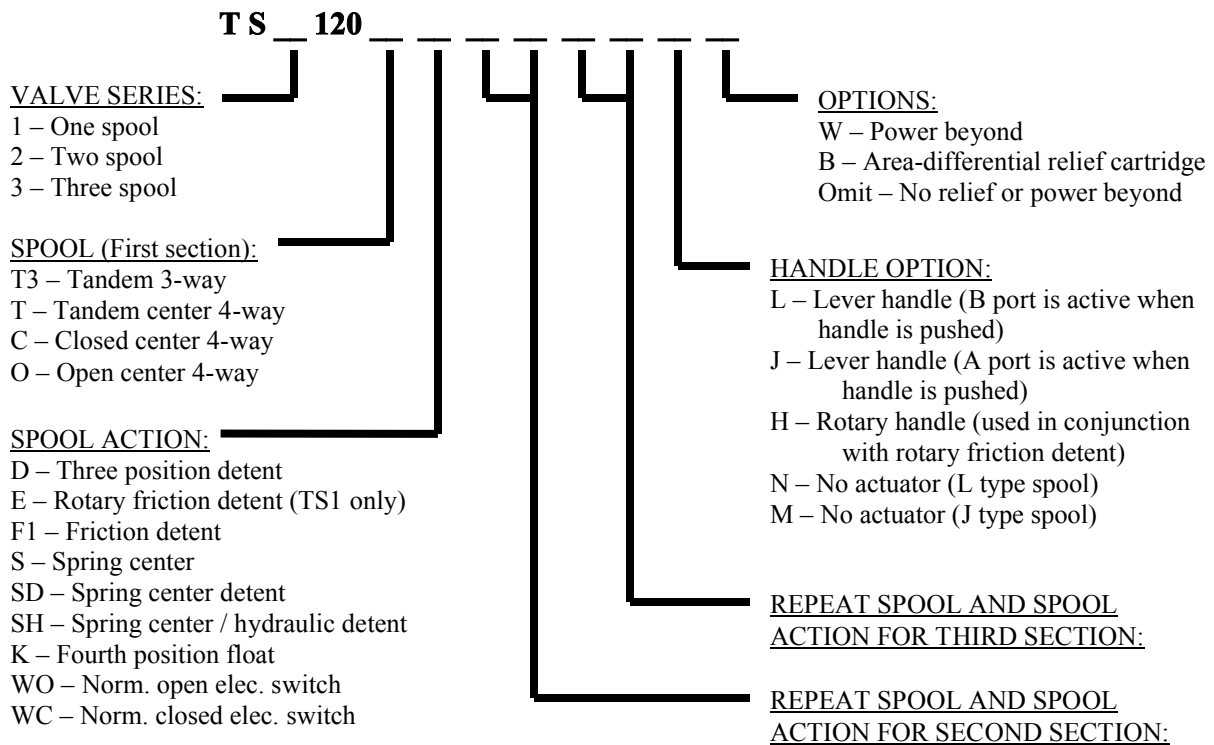

TS – COMPLETE LIST OF OPTIONS AND ACCESSORIES:

- 34R10**..... Area differential relief cartridge set at 1000 psi (69.0 bar). (Available in pressure setting increments of 100 psi (6.9 bar), please specify desired setting as per this example)
- TS-FL**..... Fourth position float, must be used on last spool of TS2 and TS3.
- TS-HJ**..... TS handle kit with ball knob. (One per spool)
- TS-HJBL**..... TS handle kit double bend, away, offset left with ball knob. (One per spool)
- TS-HJBR**..... TS handle kit double bend, away, offset right with ball knob. (One per spool)
- TS-HJS**..... TS straight handle kit with ball knob. (One per spool)
- TS-K**..... Seal kit for TS series. (One, two or three spools)
- TS3HL-K**..... Handle linkage kit for TS3. (Three linkages per kit)
- TS-NB**..... Plug for relief cavity.
- SDC-D**..... Three-position detent kit.
- SDC-F1**..... Ball friction detent.
- SDC-S**..... Spring centering kit.

TS – FLOW AND PRESSURE INFO: Pressure Drop vs. Flow for P to A or B

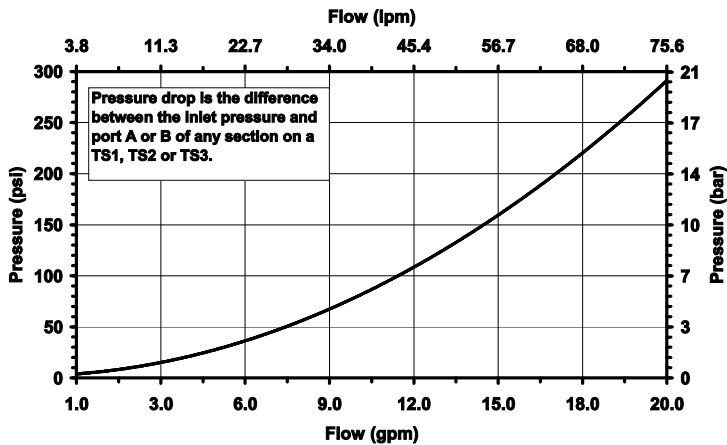

Pressure Drop vs. Flow for A or B to T

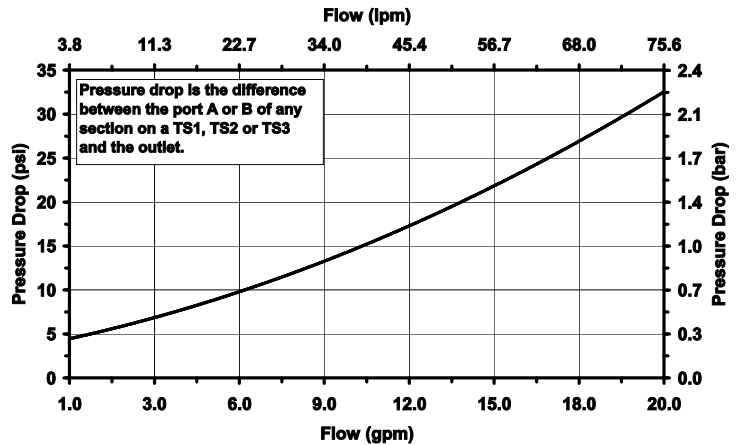

Neutral Flow Pressure Drop

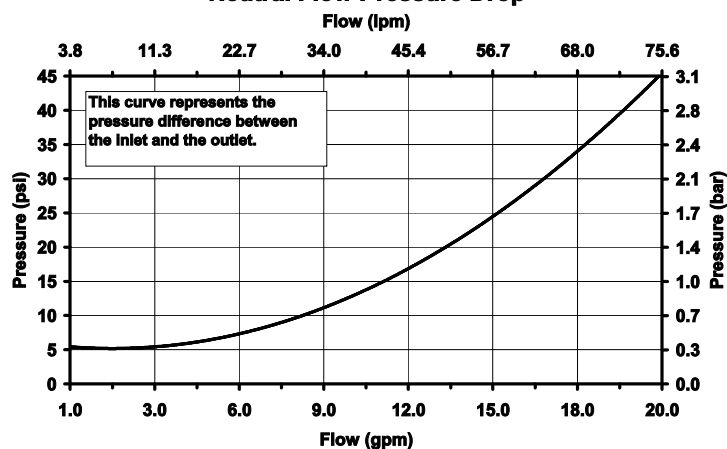

Pressure vs. Flow for Area-Differ. Port Relief (B)

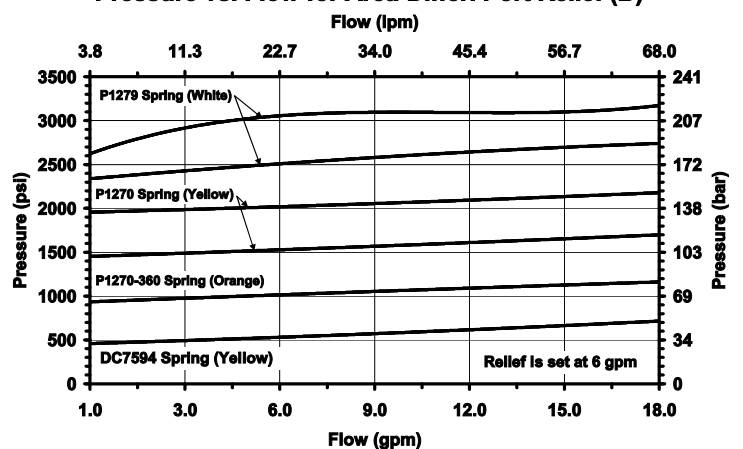

SPOOL SCHEMATICS:

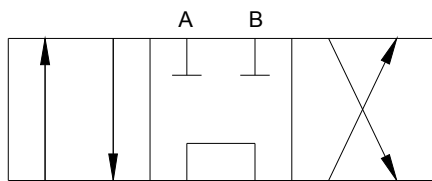

Tandem Center (T) - Powers cylinder or motor in both directions. Pump unloads to tank when spool is in neutral. Cylinder or motor blocked when spool in neutral.

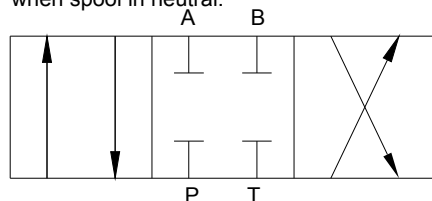

Closed Center (C)- All ports are blocked in neutral. Blocks cylinder or motor in neutral. Required for use with pressure compensated pump.

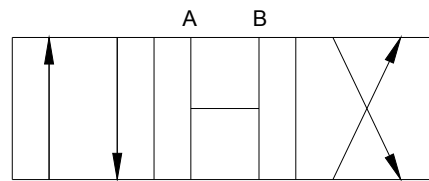

Open Center (O) - All of the ports are connected to tank when the spool is in neutral. Allows cylinder to move or motor to rotate when spool is in neutral.

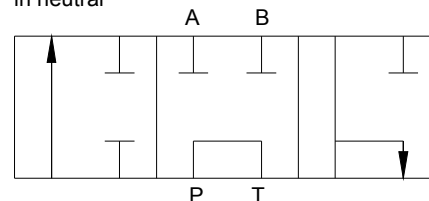

Tandem Three Way (T3) - Powers the cylinder in one direction. Pump unloads to tank when spool is in neutral, or when spool is being reversed. Cylinder is blocked when spool is in neutral. Port "B" is plugged.

DIMENSIONAL DATA: inches & [millimeters]

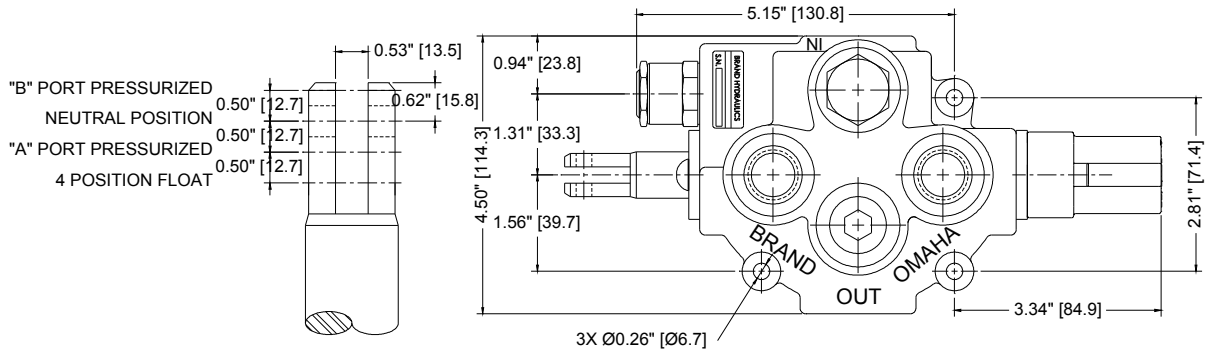

TS1120TF1JB

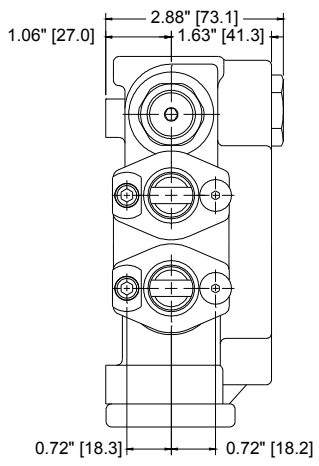

TS2120TF1TSJB

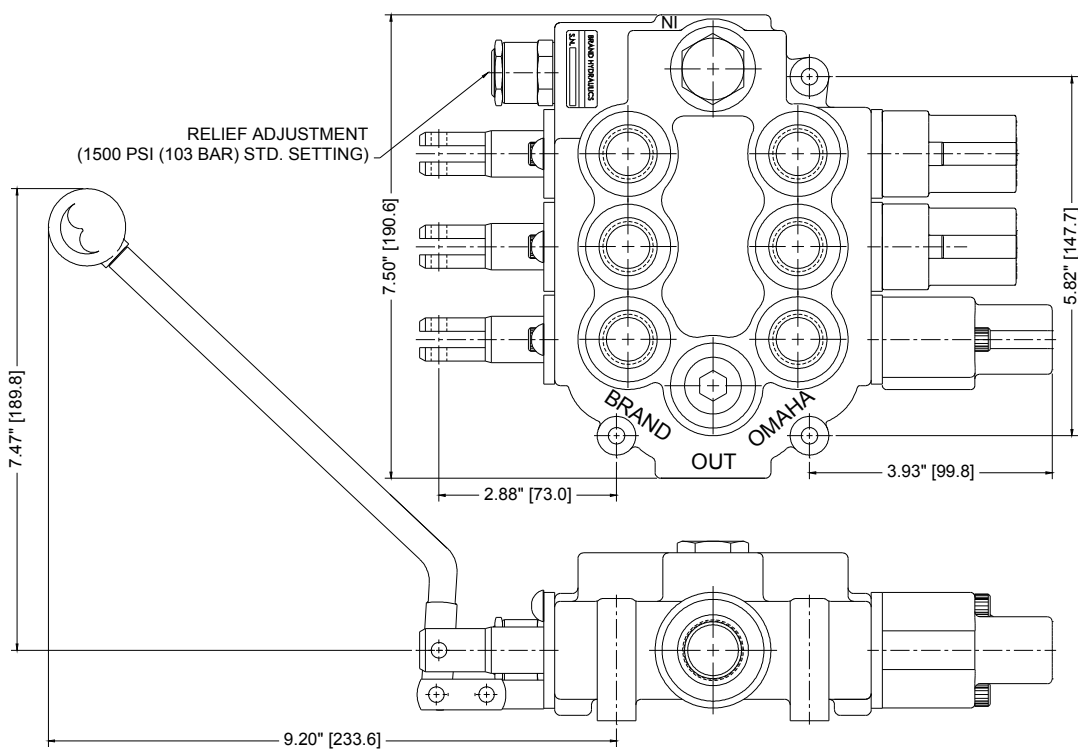
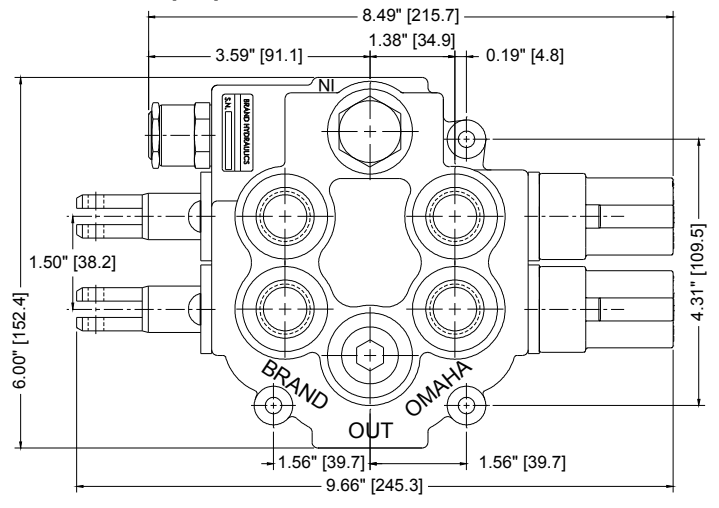

TS3120TSDTSTKJB