

SECTIONAL DIRECTIONAL CONTROL VALVE "SERIES 34"

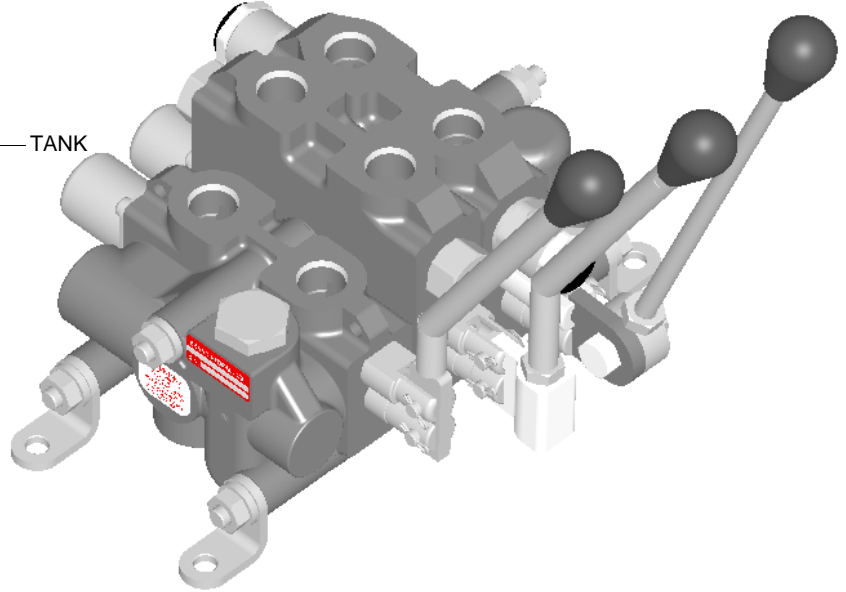
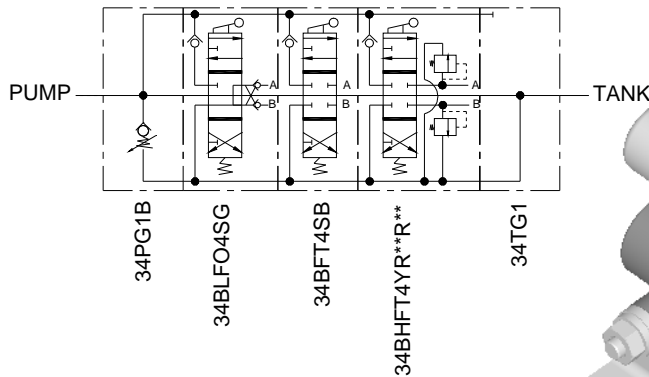

FEATURES:

- **INDIVIDUAL LOAD CHECK** built into each section that prevents the load from dropping when the spool is shifted.
- **PRECISION GROUND CHROME PLATED SPOOL** that assures long life.
- **DIAMOND HONED SPOOL BORE** provides consistent spool fit with low leakage.
- **METERING NOTCHES** give smooth control of load.
- **ADJUSTABLE HANDLES** position handle in any location from 90° up to 90° down.
- **O'RING PORTS** to eliminate leakage.
- **SPECIAL MODIFICATIONS** are easily made to fit your particular application.
- **PARALLEL OR SERIES** flow paths are possible.
- **ALL SECTIONS & ASSEMBLIES ARE 100% TESTED** includes both internal & external leakage tests & flow tests.
- **POWER BEYOND CAPABILITY** to fit your multi-valve circuits.

SPECIFICATIONS:

- **12 gpm (45.4 lpm) Nominal Capacity** (see flow chart).
- **3500 psi (241 bar).**
- **400 psi (27 bar) max tank pressure.**
- **12 sections max (consult factory for more).**
- **10 Micron Filtration Recommended.**
- **Assembly Torque = 85 inch-lbs. (9.6 N m).**
- **Weight -Inlet/outlet = 6 lbs. (2.7 kg).**
 - Low spool section = 4 lbs. (1.8 kg).
 - High spool section = 6 lbs. (2.7 kg).
- **Port Sizes** -Inlet/outlet #10SAE (7/8 - 14).
 - Work Ports #8SAE (3/4 - 16).

MATERIALS:

- **Cast Iron Body.**
- **Hard Chrome Plated Steel Spools**
- **Buna N O'Rings (standard).**
- **Stress Proof Steel Handles & Tie Rods**
- **Delrin Load Check Poppet**

SERIES 34 – GENERAL INFORMATION:

The Brand, Series 34 Sectional Directional Control Valves are assembled to meet our customer's requirements for up to twelve individual applications per assembly. Brand Hydraulics does not charge anything extra for this process and assembly is priced solely on the overall sum of the prices of its components.

When assembled in their normal manner the series 34 spool sections are in parallel. When the spools are in neutral position the flow passes by each spool and then onto the tank (outlet) port. If two or more spools are shifted simultaneously their work ports are in parallel, and the oil flow will take the path of least resistance allowing lighter loads to move first. All spool sections are cast with metering notches, and have a high "handle vs. spool" movement ratio, resulting in good metering capability. Input flow can be divided among several circuits (spool sections) by feathering the spools. Series 34 spool sections may also operate in series by installing a series block in between each spool section. Please note that when using series blocks in an assembly it is necessary to use a drain block immediately after the inlet in order for the inlet's relief to function correctly.

INLETS – can be provided with no relief, with a adjustable ball spring relief, or with an adjustable area-differential cartridge relief. Standard inlets are field convertible to be end ported (1), or top ported (2), by shifting a plug from one port to the other.

LOW SPOOL SECTIONS:

SPOOL TYPE – Open center four-way (O) connects ports A and B to tank in neutral. Tandem center four-way (T) blocks port A and B in neutral. Tandem center four-way with metering (M) blocks port A and B in neutral and meters flow when shifted. Tandem center three-way (T3) powers a cylinder in one direction. Please note that closed center four-way operation can be obtained by using a tandem center four-way spool and a closed center plug in the assembly's outlet section.

SPOOL ACTION – Standard spring center (S) returns the handle to neutral when the handle is released. Standard three-position detent (D) holds the spool in neutral and both active positions. Spring center detent (SD or DS) springs back to neutral from one position and is mechanically detented in the other direction. Fourth-position float (K) is similar to spring center except it has a fourth position that makes all ports common to each other (last spool section only). Two-position detent (D2) P to A only. Two position detent (2D) P to B only.

ACTUATORS – B-style handle (B) is non-adjustable and is the most common (use on low spool sections only). G-style handle (G) is also non-adjustable (use on any spool section). Y-style handle (Y) allows the customer to adjust the handle from straight up to straight down (use on any spool section).

OPTION –Normally open electric switch (WO) used with spring center option only. Normally closed electric switch (WC) used with spring center option only. Cable attachment (Z) used with spring center option only on spring center side (Cable actuators must have own integral centering mechanism). Jacketed cable adapter (C) allows the customer to move the spool from a remote location. Machined to attach for handle on B port side of valve (E).

HIGH SPOOL SECTIONS – are available with the same spool type, spool action, actuator and option choices as the low spool section, but offers added features such as individual port reliefs or double lock valves. Three types of reliefs are offered for high sections machined with port relief cavities – ball spring (B), area-differential (R) or area-differential with anti-cavitation check (C). Please note that all high sections require use of adjustable (Y), non-adjustable (G). Series block cannot follow a high spool section unless the working pressure for the previous sections is below 800 psi (55.1 bar).

SERIES 34 – GENERAL INFORMATION CONT...

OUTLET SECTION – is available end ported (1) which is not convertible to top port, or top ported (2) which is field convertible to end ported. Available machined for power beyond but without power beyond cartridge (A), machined for power beyond and with the power beyond cartridge (B), closed center plug (C) not available with power beyond, and field convertible open to closed center (D) without breaking open the valve stack.

ACCESSORY ITEMS – both mid-inlets and mid-outlets are available, both are available as either split flow or combined flow type.

All standard tie rod kits contain rods, foot brackets, lock washers and hex nuts. Please be sure to note correct tie rod torque spec of 85 inch lbs. (9.6 N m).

Flow restricting orifices which screw into the work ports of spool sections are available, either pressure compensated (83AFF) or non-compensated (84AFF).

Seal kits, replacement relief cartridges, series blocks, relief drain blocks and many other accessory items are available, please see the “SERIES 34 COMPLETE LIST OF OPTIONS AND ACCESSORIES” section of this catalog, for model codes and descriptions of these items.

ASSEMBLY – model codes and list prices for complete assemblies will be issued by the factory, upon request of an authorized Brand Distributor. All model codes so issued become proprietary to the requesting distributor. Model codes so issued will not be descriptive in nature, but shall be of sequential numerical type.

Individual sections and accessories can be purchased so that custom valve stacks may be assembled or modified outside the factory.

SERIES 34 – EXAMPLES OF COMMON MODEL CODES:

INLET SECTIONS

34PG1.....Inlet section plain, no relief, end ported.

34PG1B20..... Inlet section, end ported, and adjustable ball spring relief set at 2000 psi (138 bar).

OUTLET SECTIONS

34TG1.....Plain, end ported.

34TG1A..... Machined for power beyond, but less power beyond cartridge, end ported.

LOW SPOOL SECTIONS

34BFO4DB..... Open center, four-way, three-position detent, uses B-style handle.

34BFT4SB..... Tandem center, four-way, spring to center, uses B-style handle

HIGH SPOOL SECTIONS

34BHFT4SYR10R10..... Tandem center, four-way, spring to center, Y-style handle and area-differential reliefs set at 1000 psi (69.0 bar).

34BLFO4SG..... Pilot operated double lock valves, open center, four-way, spring to center and G-style handle.

SERIES 34 – EXAMPLES OF COMMON MODEL CODES CONT...

HANDLE KITS:

- 34HB**..... Standard handle kit, for spool sections with B machining option in model code.
- 34HG**..... Non-adjustable handle kit, for spool sections with G machining option in model code.
- 34HY**..... Adjustable angle handle kit, for spool sections with Y machining option in model code.

TIE ROD KITS:

- 34TR1**..... Tie rod kit for valve stack containing a standard inlet, outlet and one spool section.
- 34TR2**..... Tie rod kit for valve stack containing a standard inlet, outlet and two spool sections.

STANDARD ASSEMBLY MODEL CODES:

- 34A1B**..... Single spool assembly, tandem center four-way, spring to center action, no relief and with B style handle assembly. End ported inlet and outlet.
- 34AB1B**..... Same as above but with an adjustable ball spring relief added and set at 2000 psi (138 bar).
- 34A2B**..... Two spool assembly, tandem center four-way, spring to center action, no relief, and with B-style handle assemblies. End ported inlet and outlet.
- 34AB2B**..... Same as above but with an adjustable ball spring relief added and set at 2000 psi (138 bar).

Standard assemblies are available with up to 12 spool sections using the model code format outlined above for the one and two spool assemblies.

SERIES 34 – CREATING A MODEL CODE FOR SERIES 34:

INLET SECTION:

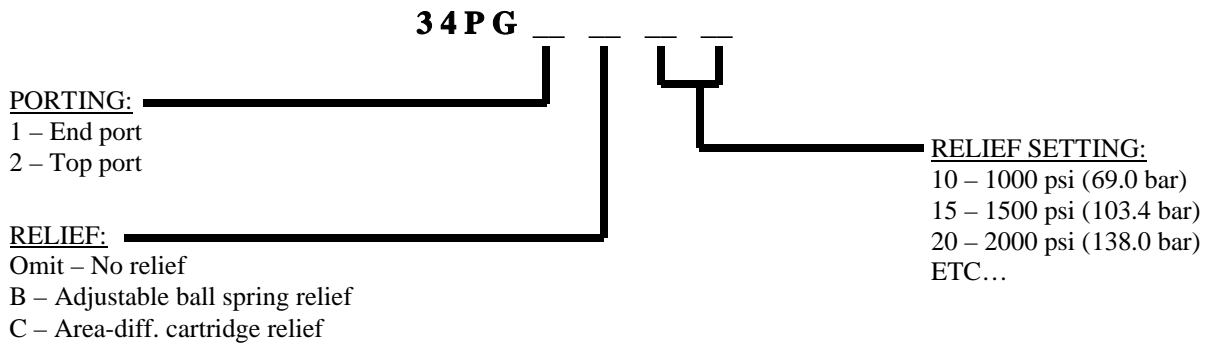

END SPOOL SECTION:

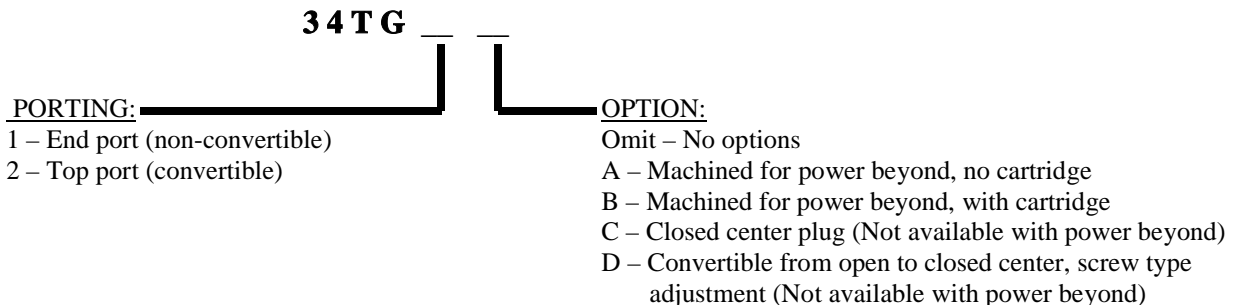

SERIES 34 – CREATING A MODEL CODE FOR SERIES 34 CONT...

LOW SPOOL SECTION:

34 B F

SPOOL TYPE:

- T – Tandem center
- O – Open center
- M – Tandem with metering (4-way only)

TYPE:

- 3 – Three-way (T spool only)
- 4 – Four-way

SPOOL ACTION:

- S – Spring center
- D – Three-position detent
- SD – Spring center (P to A) / detent
- DS – Detent / spring center (P to B)
- K – Fourth-position float / spring center (Last spool only)
- D2 – Two-position detent P to A
- 2D – Two position detent P to B

OPTION:

- WO – Normally open electric switch (Spring center only)
- WC – Normally closed electric switch (Spring center only)
- Z – Cable attachment on spring center end of valve
- C – Jacketed cable adapter
- E – Machined for handle on B port end of valve

ACTUATORS:

- B – Fixed angle handle (Standard)
- G – Fixed angle handle
- Y – Variable angle handle

HIGH SPOOL SECTION WITH LOCK(S):

34 B L F

LOCK TYPE:

- 1 – Single lock
- Omit – double lock

SPOOL TYPE:

- T – Tandem center
- O – Open center
- M – Tandem with metering (4-way only)

TYPE:

- 3 – Three-way (T spool only)
- 4 – Four-way

SPOOL ACTION:

- S – Spring center
- D – Three-position detent
- SD – Spring center (P to A) / detent
- DS – Detent / spring center (P to B)
- K – Fourth-position float / spring center (Last spool only)
- D2 – Two-position detent P to A
- 2D – Two position detent P to B

OPTION:

- WO – Normally open electric switch (Spring center only)
- WC – Normally closed electric switch (Spring center only)
- Z – Cable attachment on spring center end of valve
- C – Jacketed cable adapter
- E – Machined for handle on B port end of valve

ACTUATORS:

- G – Fixed angle handle
 - Y – Variable angle handle
- Note: B-style handle not available on high sections

HIGH SPOOL SECTION WITH PORT RELIEF(S):

3 4 B H F

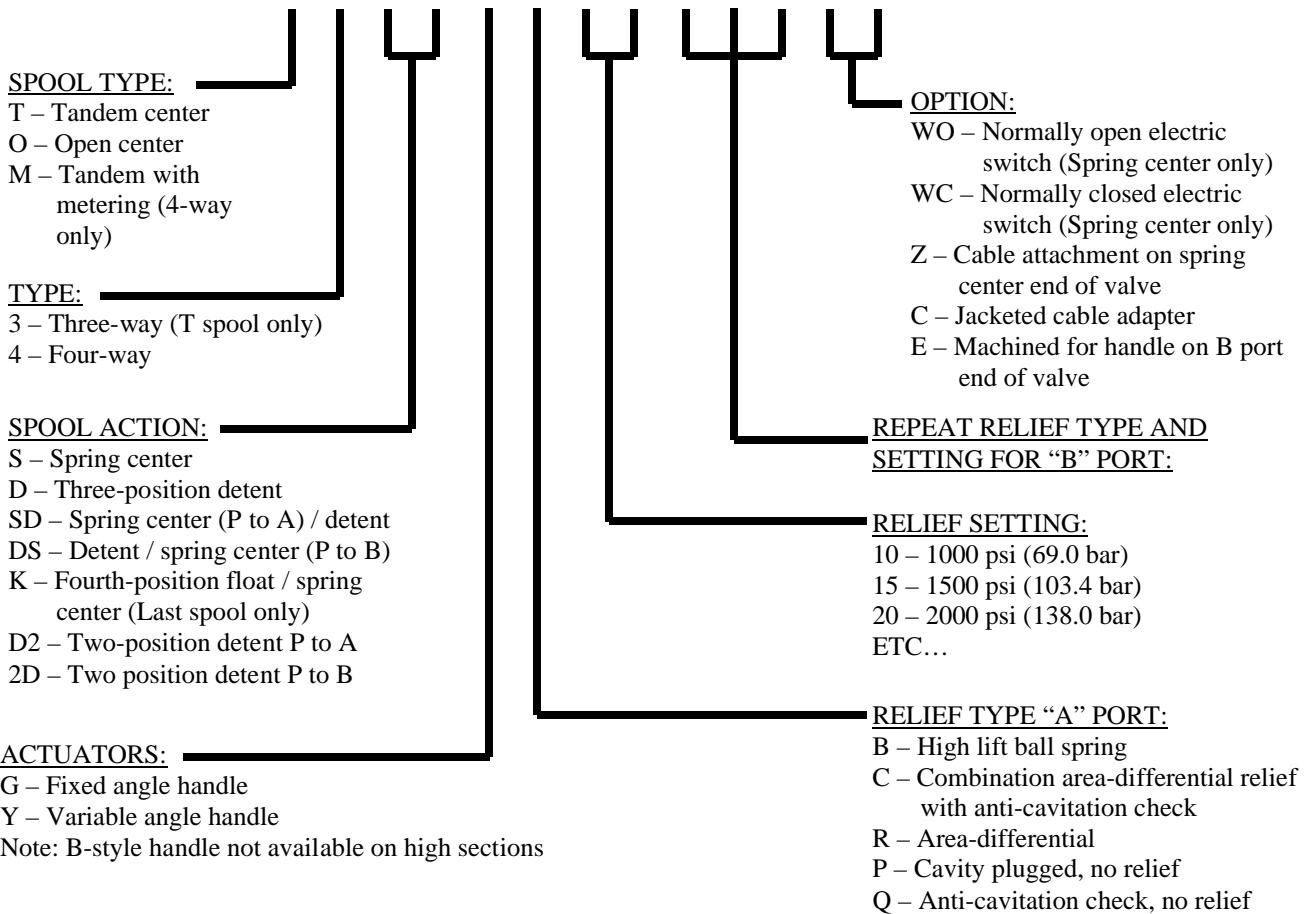

SERIES 34 – COMPLETE LIST OF OPTIONS AND ACCESSORIES:

- 34K**..... Fourth position float kit, use on last spool section in assembly only.
- 34AGPB**..... Power beyond cartridge kit, for outlet sections with A or B in their model code.
- 34AWC**..... Spring to center kit with normally closed electric switch.
- 34AWO**..... Spring to center kit with normally open electric switch.
- 34AS**..... Spacer block (adds 0.75” [19.0 mm] between spool sections).
- 34ASB**..... Series block, installed in between two spool sections puts them in series (adds 0.75” [19.0 mm] between spool sections).
- 34ASD**..... Series drain block, required for inlet relief to function correctly when using series block(s) in an assembly (adds 1.598” [19.0 mm] between spool sections).
- 34ASI**..... Isolator block.
- 34ASOL**..... Mid-outlet solid block.
- 34ASP**..... Spool end adapter kit, converts spools machined to accept handles to spools having a tapped (5/16-18) end for attaching actuator cables or rods.
- 34ASPB**..... Same as 34ASP, except, with blank end (customer taps to their own spec).
- 34AZ**..... Spring to center kit with tap (5/16-18) for cable attachment (note: spring to center mechanism is intended to shift the spool only, cable actuators must have their own integral centering mechanism).
- 34AZ2**..... Same as 34AZ except tap is 1/4-28.

SERIES 34 – COMPLETE LIST OF OPTIONS AND ACCESSORIES CONT...

- 34B10**..... High lift ball spring relief cartridge, set at 1000 psi (69.0 bar), for spool section codes beginning 34BH. (Available in pressure setting increments of 100 psi (6.9 bar), please specify desired setting as per this example).
- 34BFMIC**..... Mid-inlet combined flow.
- 34BFMIS**..... Mid-inlet split flow.
- 34BFMOI**..... Mid- outlet/inlet (flow exits out A port, and is accepted back in at B port).
- 34BFMOS**..... Mid-outlet split flow.
- 34BHFMIC**..... Mid-inlet, combined flow, with cavities for port reliefs. Port relief cartridge options and call outs are the same for this unit as those for the 34BH type high spool sections.
- 34BHFMS**..... Mid-inlet, split flow, with cavities for port reliefs. Port relief cartridge options and call outs are the same for this unit as those for the 34BH type high spool sections.
- 34C10**..... Combination area-differential relief / anti-cavitation check cartridge, set at 1000 psi (69.0 bar), for spool section codes beginning 34BH. (Available in pressure setting increments of 100 psi (6.9 bar), please specify desired setting as per this example.)
- 34CK**..... Seal kit for series 34 area-differential relief cartridges.
- 34CP**..... Relief port cavity plug, for spool section codes beginning 34BH.
- 34D**..... Three-position detent kit, for low or high spool section.
- 34D2**..... Two-position detent kit, pressure to A port in the detent position.
- 34D2**..... Two-position detent kit, pressure to B port in the detent position.
- 34DS**..... Detent kit, spool is detented in one work position (P to A), and springs to center from the other.
- 34SD**..... Same as 34DS but detent and spring center directions are reversed (P to B when spool detented).
- 34HB**..... B-style handle kit, with bent handle, use on spool sections with (B) handle call out.
- 34HBS**..... B-style handle kit, with straight handle, use on spool sections with (B) handle call out.
- 34HB-90**..... B-style handle kit, with handle bent at 90 degrees, use on spool sections with (B) handle call out.
- 34HG**..... G-style handle kit, with bent handle, use on spool sections with (G) handle call out.
- 34HGS**..... G-style handle kit, with straight handle, use on spool sections with (G) handle call out.
- 34HY**..... Y style handle kit, handle angle adjusts to clear relief and lock cartridges in high spool sections, or to facilitate “handle through panel” mounting of valve assemblies. Please note that different length handle rods can be furnished, contact factory for details. Standard rod length is 9.41”.
- 34Q**..... Anti-cavitation check cartridge, no relief included in this kit.
- 34R10**..... Area differential relief cartridge, set at 1000 psi (69.0 bar), for spool section codes beginning 34BH, and inlets with C in model code. (Available in pressure setting increments of 100 psi (6.9 bar), please specify desired setting as per this example)
- 34S**..... Spring to center kit, for low or high spool section.
- 34TR**..... Tie rod kits, specify number of spool sections in valve assembly, i.e. 3 spool sections in valve assembly, requires using 34TR3 tie rod kit. Please note that when using extra items in the assembly, such as series blocks, drain blocks, isolator blocks etc., the tie rod kit must have its length extended.
- 83AFF01**..... Pressure compensated flow control, set at 1 gpm (3.8 lpm), screws into work port of any spool section, meters flow into said port. (Available in whole gallon increments to 10 gpm (37.8 lpm), please specify desired setting as per this example.)
- 84AFF**..... Non-pressure compensated flow control, specify orifice size required in blank (i.e. 84AFF.50).
- P1156**..... Closed center plug, installs in any basic outlet except ones with D in model code. (Cannot be used with power beyond)
- P14605S-K**..... Series 34 Pilot Operated Check Seat

Seal Kits:

- 34AK**..... Replacement seal kit for basic low spool section.
- 34BK**..... Seal kit, contains seals for use in between spool sections.
- 34BLF-K**..... Seal kit, contains seals and check seat for 34BL2F work section.
- 34CK**..... Seal kit for series 34 area-differential relief cartridges.

Please feel free to contact the factory with your ideas regarding custom options or accessories, we will be happy to review them to see if they can be put into production for your assemblies.

SERIES 34 FLOW AND PRESSURE INFO:

Pressure Drop vs. Flow for Inlet Ball Spring Relief

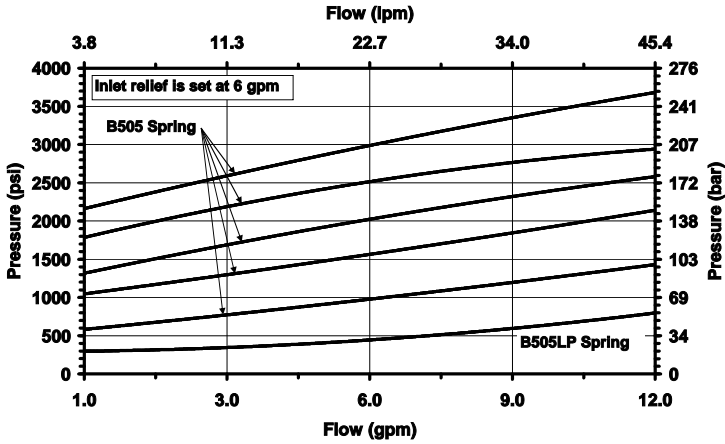

Pressure Drop vs. Flow for S34 Relief

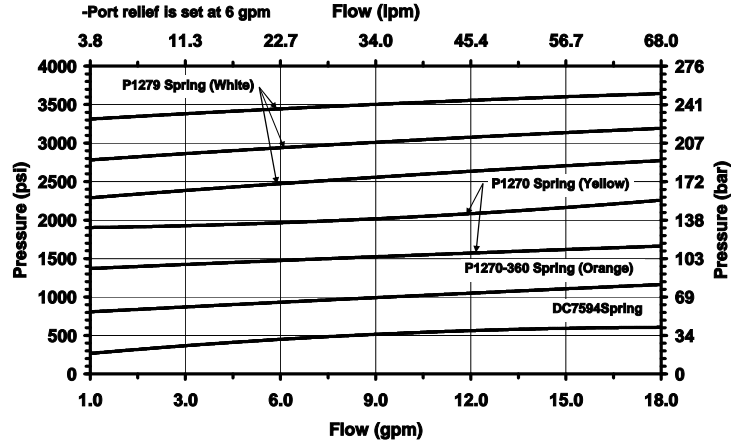

Pressure Drop vs. Flow for A or B-T

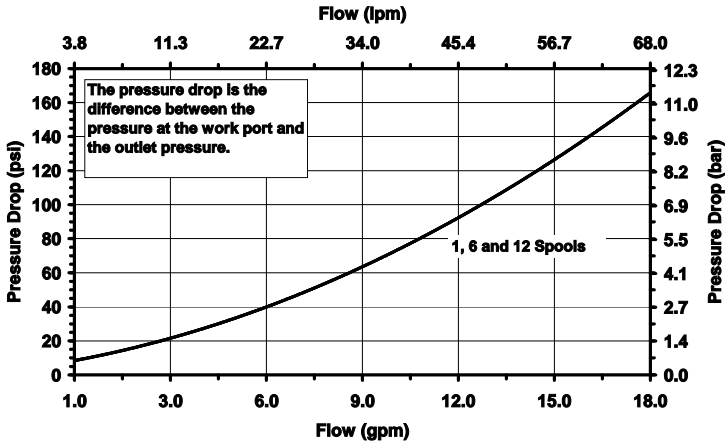

Pressure Drop vs. Flow for P-A or B

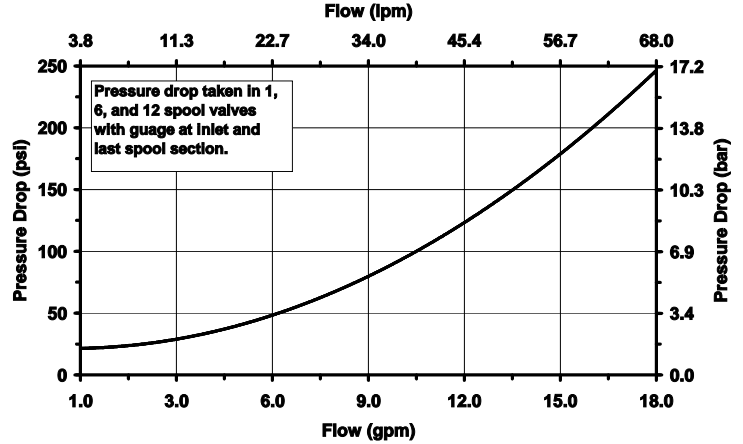

Pressure Drop vs. Flow for P-T

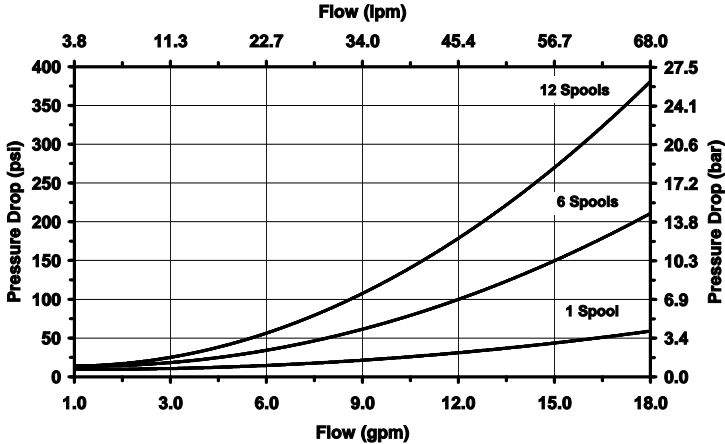

Pressure Drop for High Sections

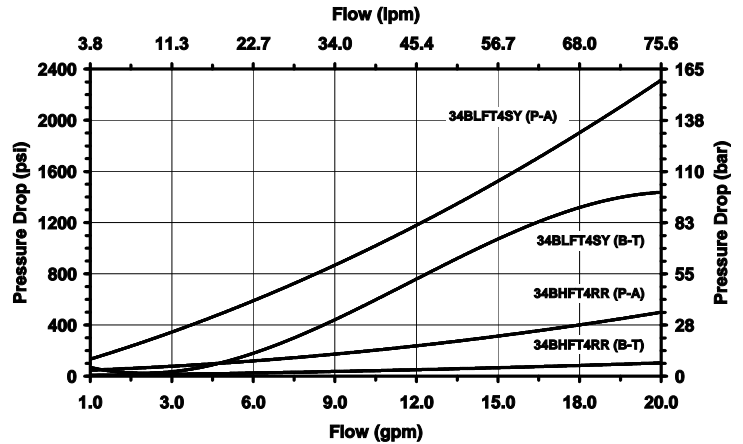

DIMENSIONAL DATA: inches & [millimeters]

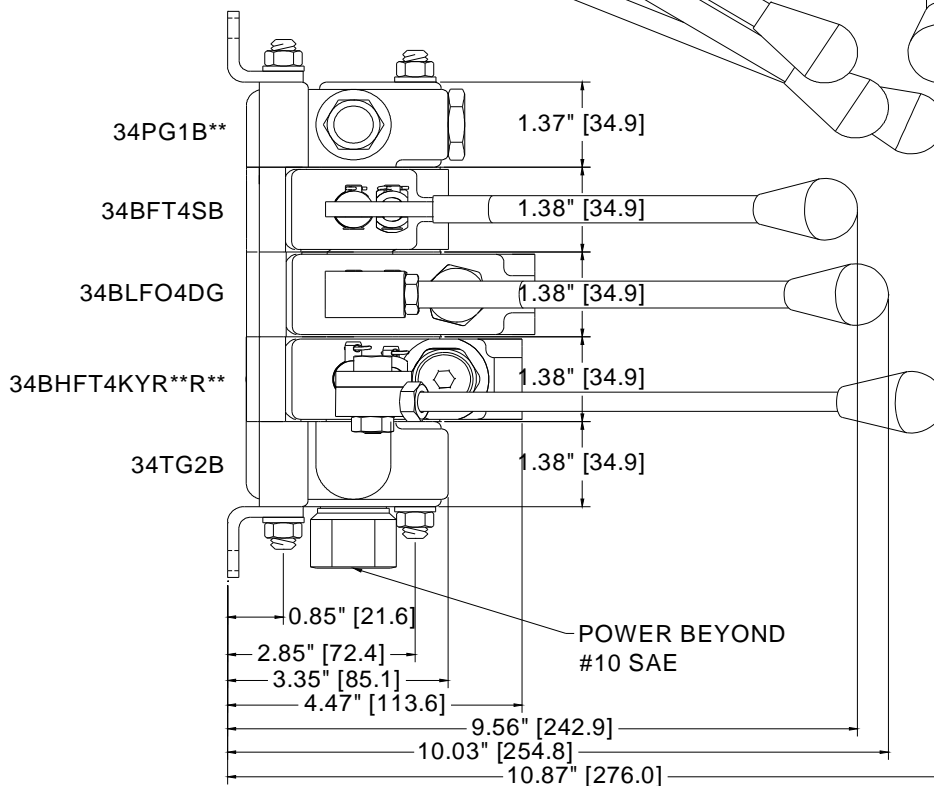
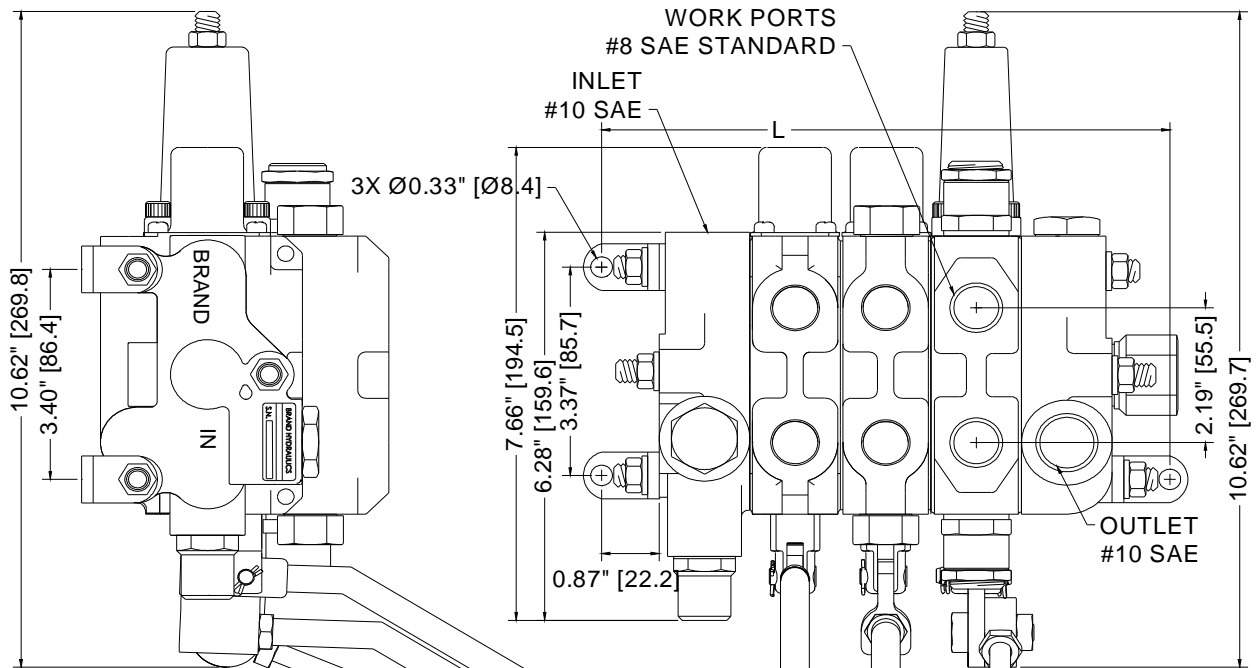

| # OF SPOOLS | L |
|-------------|----------------|
| 1 | 5.87" [149.1] |
| 2 | 7.25" [184.0] |
| 3 | 8.62" [218.9] |
| 4 | 10.00" [253.9] |
| 5 | 11.37" [288.8] |
| 6 | 12.75" [323.7] |
| 7 | 14.12" [358.6] |
| 8 | 15.50" [393.6] |
| 9 | 16.87" [428.5] |
| 10 | 18.25" [463.4] |
| 11 | 19.62" [498.3] |
| 12 | 21.00" [533.3] |



VALVE ASSEMBLY ARRANGEMENT:

| | | PRICE |
|-----------|--|--------------|
| | 34A _____ | |
| INLET | 34PG _____ | |
| SPOOL #1 | 34B _____ | |
| SPOOL #2 | 34B _____ | |
| SPOOL #3 | 34B _____ | |
| SPOOL #4 | 34B _____ | |
| SPOOL #5 | 34B _____ | |
| SPOOL #6 | 34B _____ | |
| SPOOL #7 | 34B _____ | |
| SPOOL #8 | 34B _____ | |
| SPOOL #9 | 34B _____ | |
| SPOOL #10 | 34B _____ | |
| SPOOL #11 | 34B _____ | |
| SPOOL #12 | 34B _____ | |
| OUTLET | 34TG _____ | |
| MISC. | _____ | |
| TIE ROD | 34TR _____ <small>(Torque to 85 inch lbs (9.6 N m))</small> | |
| HANDLES | 34H _____ QNTY. _____ XPRICE _____ = \$ _____ | |
| ASSEMBLY | 34A _____ LIST \$ _____ | |

DISTRIBUTOR: _____

ADDRESS: _____

CITY: _____ **STATE:** _____ **ZIP:** _____ **DATE:** _____