

Product Modifications and Additions

FC51 and FCR51 Product Improvements:

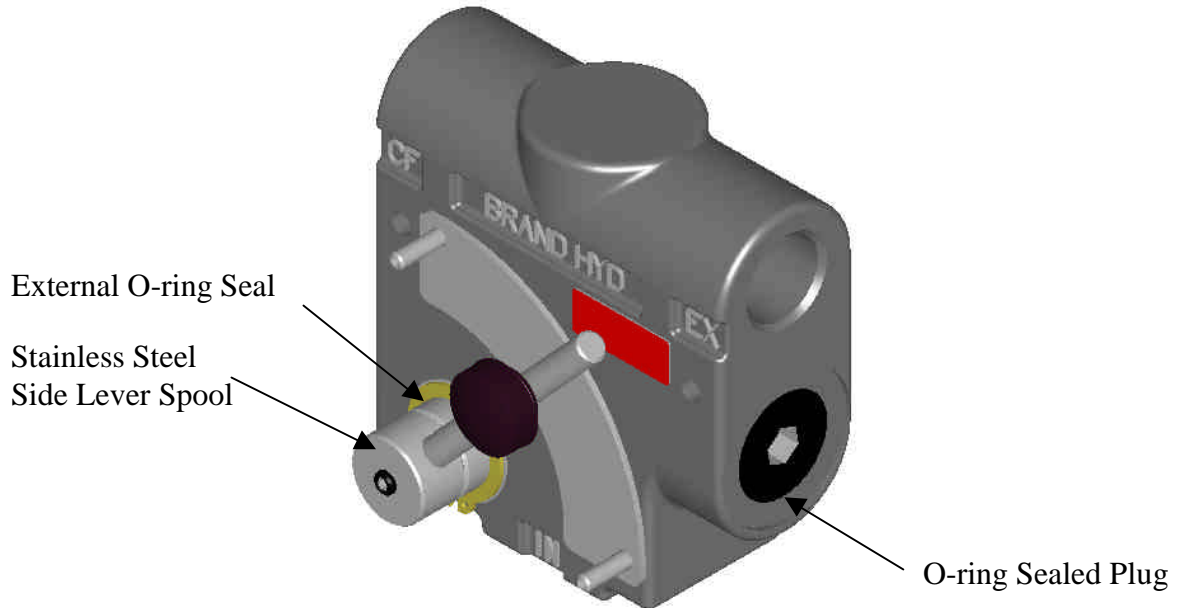

Brand Hydraulics has listened to its distributors and increased the value of the FC/FCR series while maintaining its competitive price. First, Brand changed the material of the side lever spool to stainless steel to eliminate any seizing of the side lever due to corrosion. All FC and FCR's now come standard with SS spools at no additional cost (Note: SS nomenclature has been removed from the model code). Next, Brand added an additional o-ring (P1659) to eliminate corrosion between the side lever and casting bore (In the area marked "X" which is outside the main o-ring groove (B5024)). Finally, Brand changed the two plugs on the compensator bore from pipe thread to straight thread to eliminate external leakage and increase consistency from valve to valve. To Brand's knowledge no one else has combined all three of these improvements on their flow control.

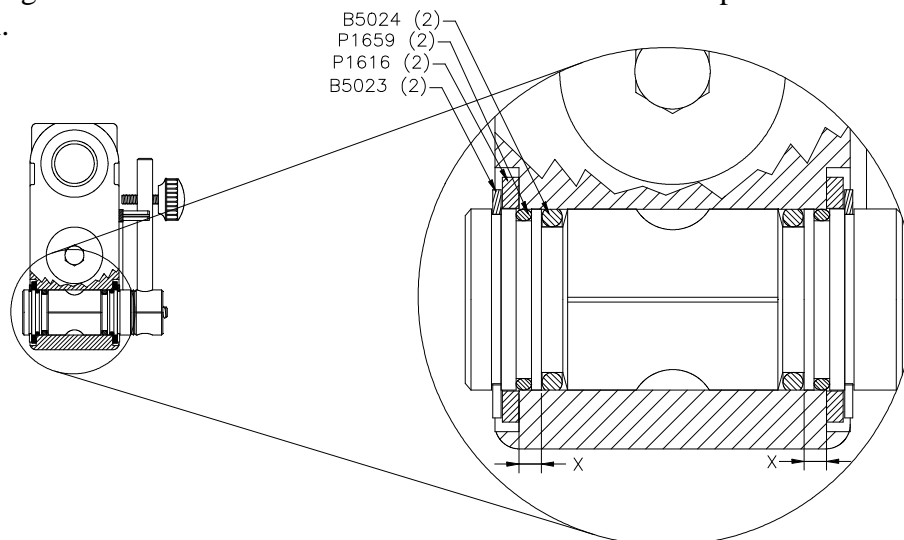

MANUFACTURERS OF SPECIAL FLUID POWER PRODUCTS

(Over)

Series 36 Handle Improvements:

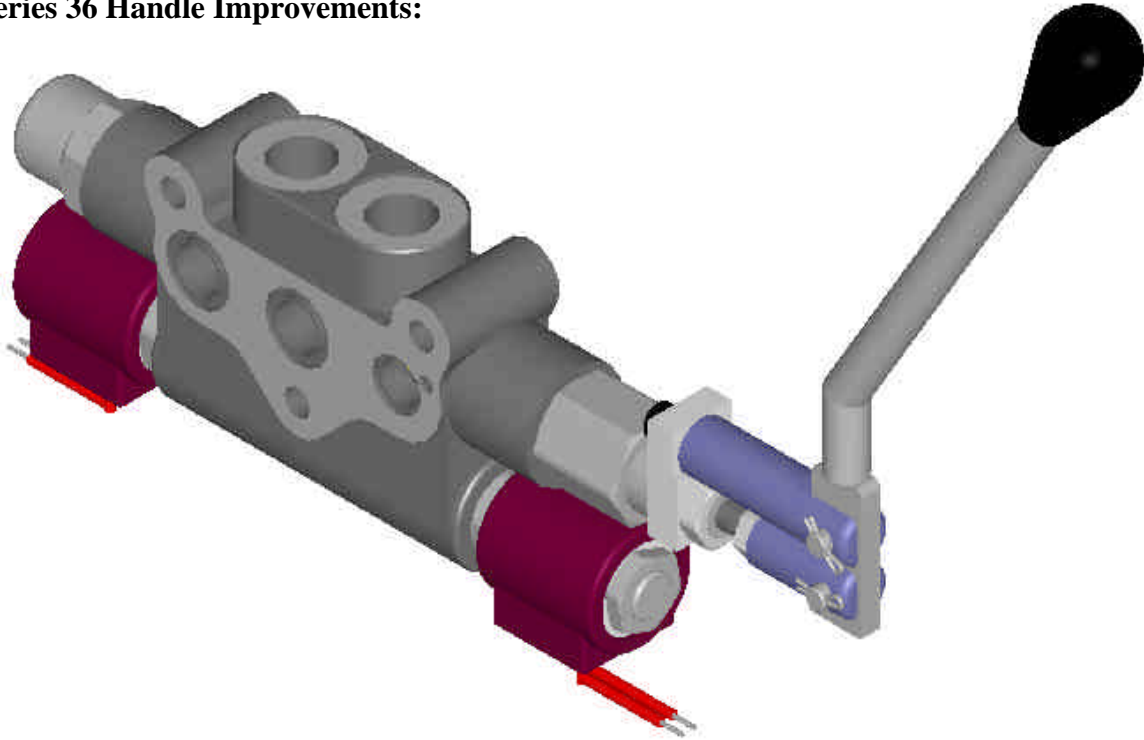

Brand Hydraulics has redesigned the Series 36 handle to increase durability, cycle life and reduce handle play. The handle rod (P1852) is heat-treated, ground, chrome plated and then ground again to provide the smoothest finish possible. A poly-pak seal is used to seal the handle rod because it wipes any fluid off the handle rod and provides a high cycle life. It is not necessary to change any model codes when ordering because this design replaces the old design.

