

INSTALLATION SHEET FOR DCF DIRECTIONAL CONTROL VALVES

KEEP WITH PRODUCT UNTIL INSTALLED

ADDITIONAL SHEETS MAY BE PRINTED OUT FROM OUR WEBSITE WWW.BRAND-HYD.COM UNDER PRODUCT CATALOG SECTION

How do I adjust pressure relief?

First, remove the round plug above the outlet port with an Allen wrench (0.125") and set aside. This gives you access to the relief set screw (0.1875"); for every ½ **clockwise rotation** of this screw **increases** the pressure approximately 300psi.

Can I paint my valve? – Painting valves is okay as long as the following precautions are taken: 1- All ports must be plugged and 2- the spool must be masked or taped off completely. Any paint on the spool will cause leakage when it chips off. Warranty is void if any valve is returned with paint on the spool.

How do I assemble the handle to the valve?

To install the handle, place the ball end of the handle in the spool and then join the handle and the retainer using the supplied pin.

Note: Unless specified, the retainer's placement is defaulted so the handle points up when the valve is placed on a flat surface. To change this, prior to handle installation, the screws holding the retainer must be removed and the retainer can then be rotated 180° around the valve.

Mounting Surface – The valve must be mounted on a flat surface. It is important not to bend or twist the casting when mounting because this may cause the comp spool to bind.

Other Information – Valves are available in NPT and SAE, however, we do recommend SAE porting.

Pipe thread sealant – Warranty is void when Teflon tape is used to seal pipe threads. This is because Teflon tape is a friction reducing agent which allows customers to over-torque fittings. We recommend using a sealant that does not include friction reducing agents i.e. Lead Plate.

All DCF's are built with Iosso plated spools to help prevent the spools from locking up when they are in a corrosive environment. For highly corrosive environments, i.e. marine applications, we recommend using a stainless steel spool. To order a valve with a stainless steel spool simply add "SS" to the end of the model code.

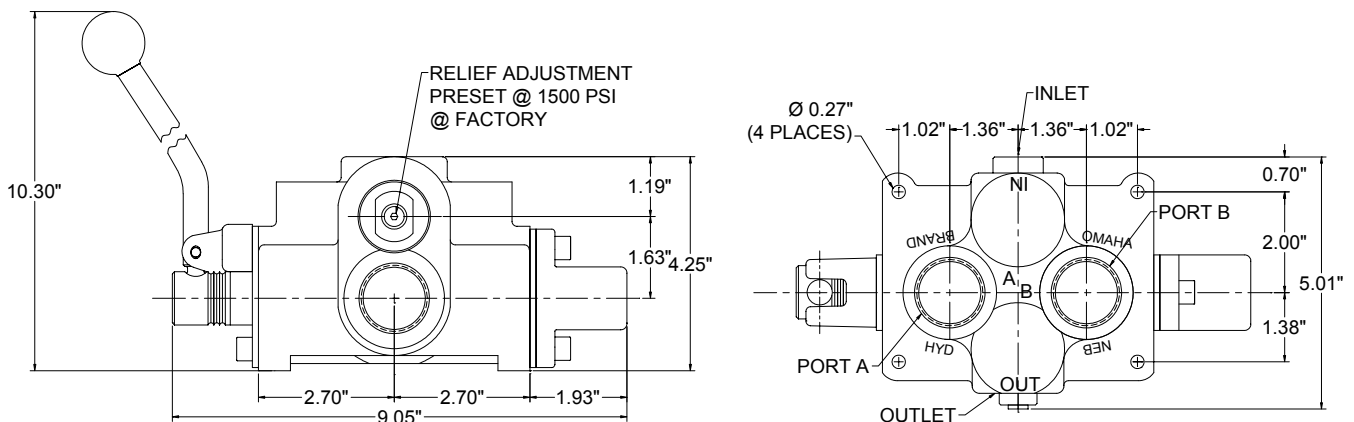

Figure 1: Dimensions for DCF valve, L-style handle shown in standard position