

4 – WAY DIRECTIONAL CONTROL VALVE

“AO”

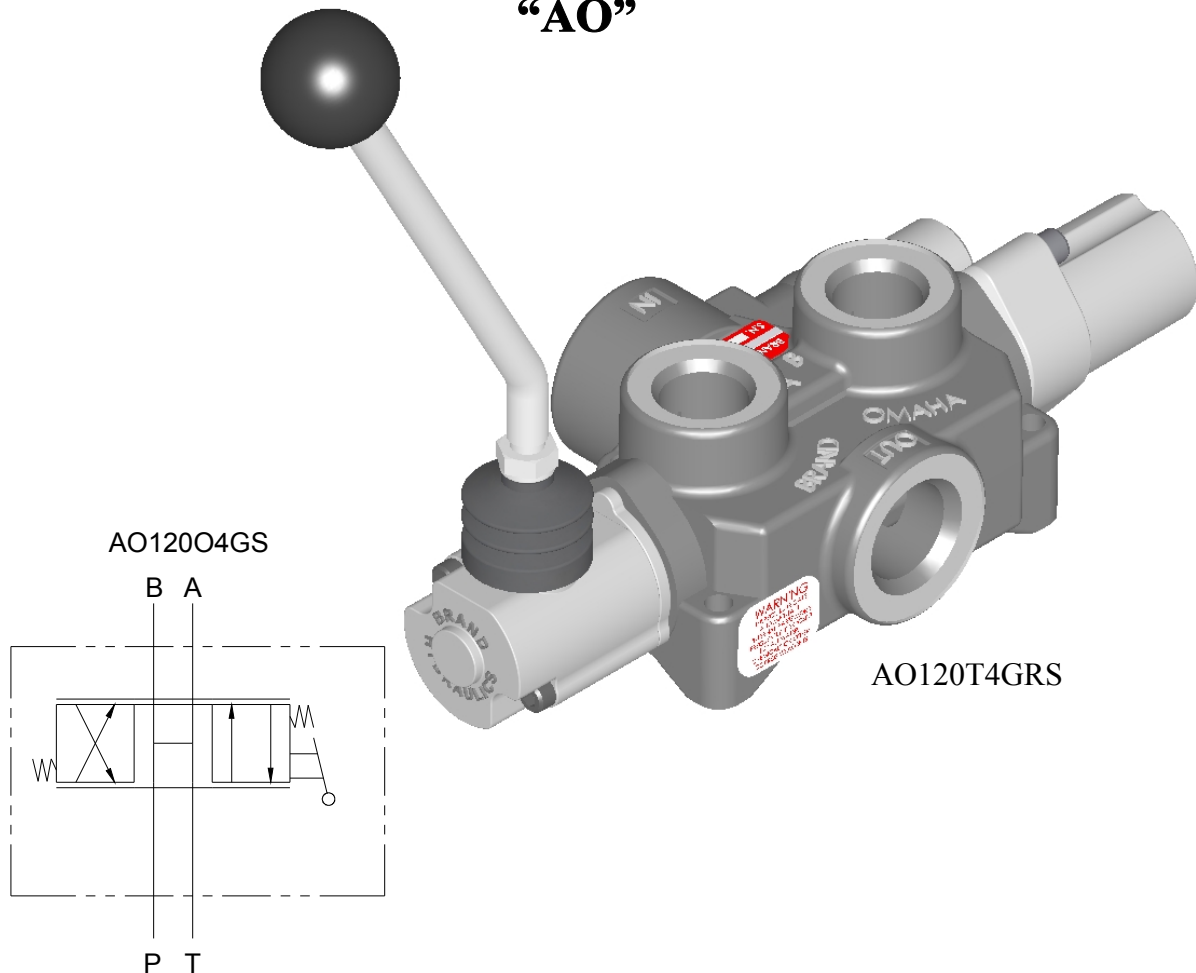

FEATURES:

- **SMALL AND COMPACT** to fit your design requirements.
- **POSITIVE METERING** in either direction with the manually shifting handle.
- **PRECISION GROUND IOSSO PLATED SPOOL** that assures long life.
- **OPTIONAL O’RING PORTS** to eliminate leakage.

SPECIFICATIONS:

- **Rated for 0-18 gpm (0-68.1 lpm).**
- **Rated for 3000 psi (207 bar).**
- **Weights 5-1/2 lbs. (2.5 kg).**
- **Std. Port sizes (Consult factory for others).**
 - **3/4”NPT Inlet/outlet and 1/2” NPT work ports.**
 - **#12SAE Inlet/outlet and #10SAE work ports.**
- **30 – Micron filtration recommended.**

MATERIALS:

- **Cast Iron Body**
- **Buna N O’Rings**
- **IOSSO Plated Steel Spool**
- **Consult Factory for Stainless Steel Spools**
- **Black Nylon Ball Knob**

AO – GENERAL INFORMATION:

The Brand, 4-way directional control valve is designed to be durable and dependable. The manually shifted handle provides metered flow to either port. Port flow is directly proportional to the movement of the lever. The tank port must go directly back to tank.

SPOOL TYPE – The spool types offered are tandem center 4-way (T), open center 4-way (O), fine metering (M), tandem metering (TM), closed center 4-way (C), and tandem 3-way (T3). (See chart on next page and schematics on page #4 for information on spool types)

ACTUATORS – Standard enclosed lever handle (G) pressurizes the B port when the handle is pushed towards the valve body (vertical mount). Enclosed lever handle (C) is similar to (G) except horizontal mount. Lever handle (L) pressurizes the B port when the handle is pushed towards the valve body. Lever handle (J) pressurizes A port when the handle is pushed towards the valve body. Pilot operated (P) is used to shift the valve from a remote location. Rotary handle (H) is used to rotate spool in or out of valve body. No actuator (N) uses G type spool. No actuator (M) uses J type spool.

SPOOL ACTION – Three-position detent (D) holds the spool in neutral and both active positions. Friction detent (F1) applies friction to the spool so that the spool does not move when the handle is released either side of neutral, a detent groove clearly indicates neutral position. Spring center (S) returns the handle to neutral when the handle is released. Spring center detent (SD) springs back to neutral from one position and is mechanically detented in the other position (flow out port A in detent). Spring center friction detent (SF1) springs back to neutral from one direction and functions similar to standard F1 in other direction (flow out port B in friction detent). Spring offset (SO) spring holds spool in one active position (P to B in offset position and neutral). Spring offset (SO2) spring holds spool in one active position (P to B in offset position, neutral and P to A). Rotary friction detent (E) applies friction to the spool as it is rotated so that the spool does not rotate when the handle is released either side of neutral, a detent groove clearly indicates neutral position. Two-position detent (2D) P to B only. Two-position detent (D2) P to A only. Adjustable relief (R) set to 1500 psi (103 bar) at factory. Normally closed electric switch (WC) used with (S), (F1) and (D) options only. Normally open electric switch (WO) used with (S), (F1) and (D) options only.

AO – EXAMPLES OF COMMON MODEL CODES:

AO755T4GRS..... 3/4" inlet and outlet ports, 1/2" work ports, tandem center 4-way spool, G style handle, adjustable relief set at 1500 psi (103 bar) and spring centering.
AO755O4GD..... 3/4" inlet and outlet ports, 1/2" work ports, open center 4-way spool, G style handle, and three position detent.

AO – COMPLETE LIST OF OPTIONS AND ACCESSORIES:

SDC-D..... Three-position detent kit.
SDC-F1..... Ball friction detent.
SDC-S..... Spring centering kit.
SDC-SD..... Spring centering detent kit (P to A in detent).
SDC-SF1..... Spring center / friction detent (P to B in friction detent).
SDC-SO..... Spring offset kit (P to B in offset position and neutral).
SDC-SO2..... Spring offset kit (P to B in offset position, neutral and P to A).
SDC-SWC..... Spring centering kit with normally closed electric switch.
SDC-SWO..... Spring centering kit with normally open electric switch.
SDC-WC..... Three-position detent kit with normally closed electric switch.
SDC-WO..... Three-position detent kit with normally open electric switch.
SDC-F1WC..... Ball friction detent with normally closed electric switch.
SDC-F1WO..... Ball friction detent with normally open electric switch.
SDC-HG..... G style handle kit.
SDC-HJ..... J style handle kit.
SDC-HL..... L style handle kit.
SDC-K..... Seal kit for AO.

AO – CREATING A MODEL CODE FOR AO'S:

A O

PORT SIZE:

755 – 3/4" inlet/outlet and 1/2" work ports
 120 – #12SAE inlet/outlet and #10SAE work ports

SPOOL TYPE:

T – Tandem center
 O – Open center
 C – Closed center
 T3 – Tandem 3-way
 M – Fine metering
 TM – Tandem metering

FLOW SETTING:

Omit – When using T, C, T3 and O spool
 6 – 6 gpm (0-22.7 lpm) M and TM only
 12 – 12 gpm (0-45.4 lpm) M and TM only
 18 – 18 gpm (0-68.0 lpm) M and TM only

3-WAY OR 4-WAY:

3 – 3-way (Tandem spool only)
 4 – 4-way

SPOOL ACTION:

S – Spring center
 D – Three-position detent
 F1 – Ball friction detent
 WC – Norm. close elec. switch (use for S, D and F1)
 WO – Norm. open elec. switch (use for S, D and F1)
 SO – Spring offset (P to B and neutral)
 SO2 – Spring offset (P to B, neutral and P to A)
 SD – Spring center / detent
 SF1 – Spring center / friction detent (P to B in friction detent)
 2D – Two-position detent P to B
 D2 – Two-position detent P to A
 F2 – Two-position friction P to A
 F2M – Two-position friction P to A with stroke limiter
 E – Rotary ball friction detent
 M – Stroke limiter
 R – Adjustable relief

HANDLE OPTION:

G – Enclosed handle (B port is active when handle is pushed, recommended)
 C – Enclosed handle (horizontal mount)
 L – Lever handle (B port is active when handle is pushed)
 J – Lever handle (A port is active when handle is pushed)
 P – Pilot operated
 N – No actuator (G type spool)
 M – No actuator (J type spool)
 H – Rotary handle (Used in conjunction with rotary ball friction detent (E))

AO – FLOW AND PRESSURE INFO:

Pressure Drop vs. Flow

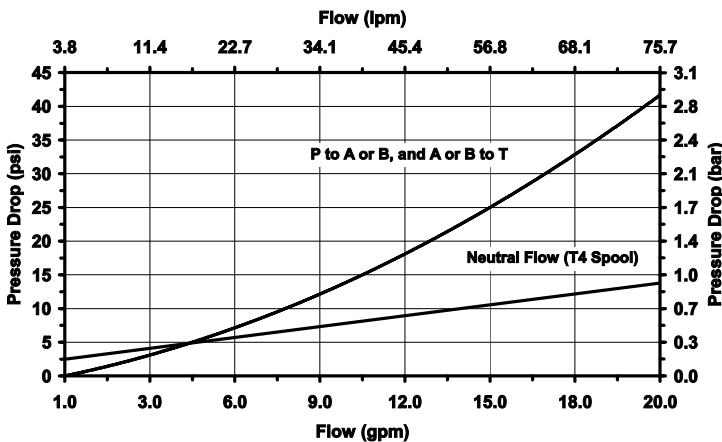

Pressure vs. Flow for AO Relief (R)

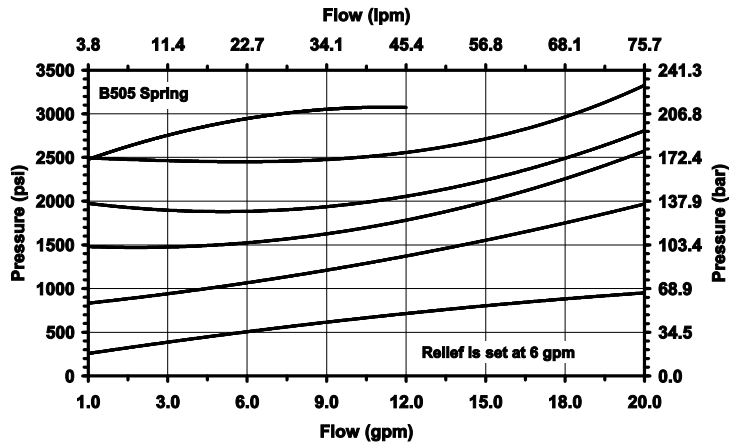

SPOOL SCHEMATICS:

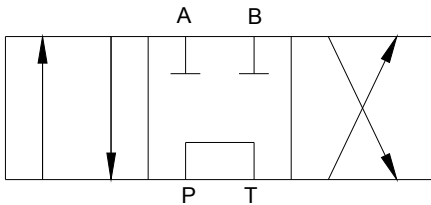

Tandem Center (T) - Powers cylinder or motor in both directions. Pump unloads to tank when spool is in neutral. Cylinder or motor blocked when spool is in neutral.

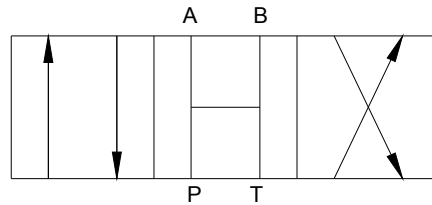

Open Center (O) - All of the ports are connected to tank when the spool is in neutral. Allows cylinder to move or motor to rotate when spool is in neutral.

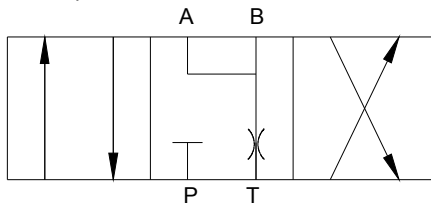

Fine Metering Spool (M) - Requires external locking valves to hold cylinder when spool is in neutral position. Extremely fine metering control. This spool requires a pressure compensated pump.

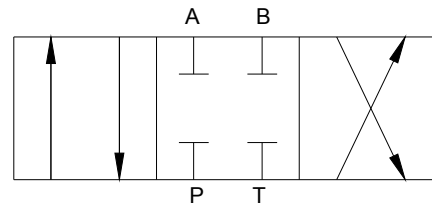

Closed Center (C) - All ports are blocked in neutral. Blocks cylinder or motor in neutral. Required for use with pressure compensated pump.

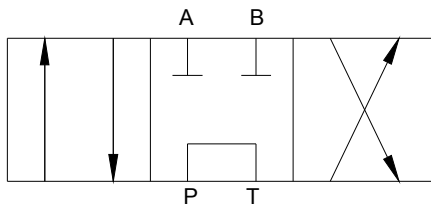

Tandem Metering Spool (TM) - Similar to (T) spool except much finer metering control. Cylinder or motor blocked in neutral and pump unloads to tank.

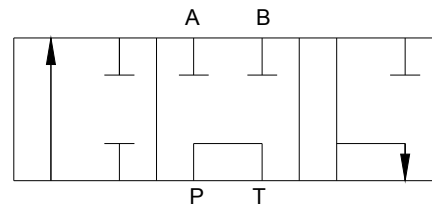

Tandem Three Way (T3) - Powers the cylinder in one direction. Pump unloads to tank when spool is in neutral, or when spool is being reversed. Cylinder is blocked when spool is in neutral. Port "B" is plugged.

DIMENSIONAL DATA (AO120T4GRS SHOWN): inches & [millimeters]

