

SERIES 36-38 AND EFC VALVE PACKAGE "36EFC"

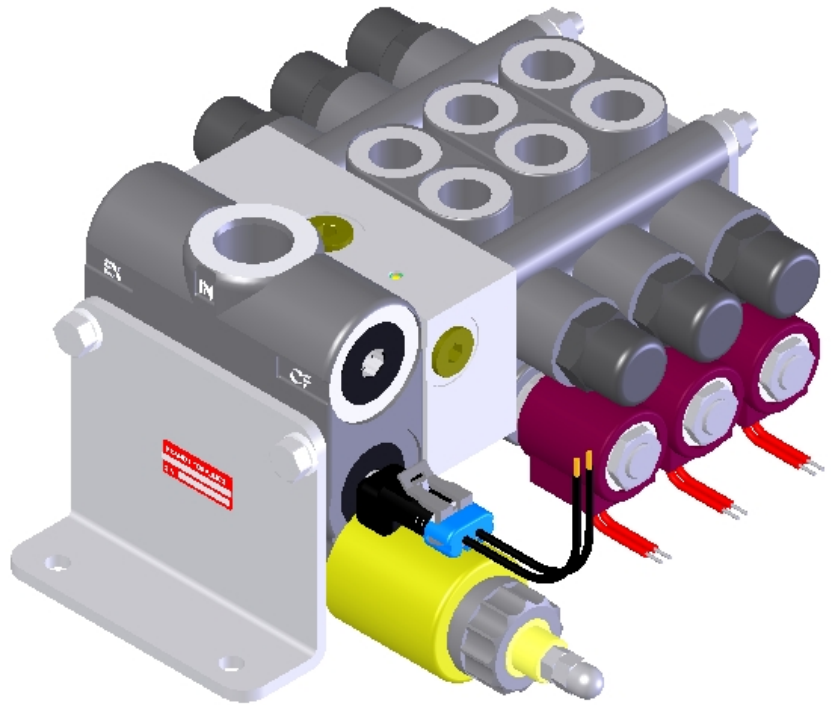
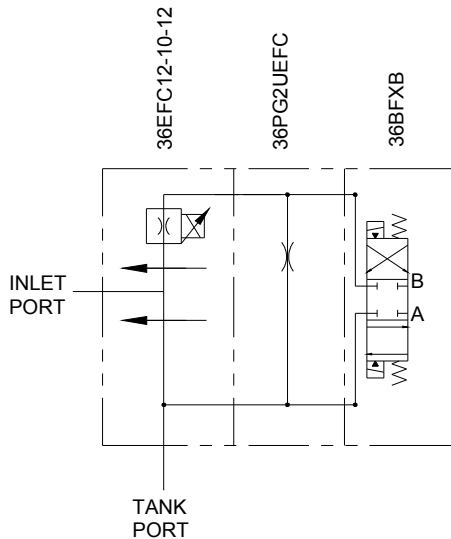

FEATURES:

- **ADAPTABLE TO AUTOMATED CIRCUITS** for four-way directional speed control.
- **CONTROL AND WIRING HARNESS PACKAGES** available to fit customer's application.
- **OPEN OR CLOSED PACKAGES** are available to suit the customer's needs.
- **PRECISION GROUND HEAT TREATED SPOOLS** assure long life.
- **DIAMOND HONED SPOOL BORE** provides consistent spool fit with low leakage.
- **O'RING PORTS** to eliminate leakage.
- **PILOT CARTRIDGES** assures positive force to shift spool.
- **OPTIONAL HIGH LIFT RELIEF.**

SPECIFICATIONS:

- **Rated for 0-24 gpm (0-91 lpm) depending on Series 36-38 work sections used.**
- **Pressure rating 3000 psi (207 bar).**
- **10 Micron filtration recommended.**
- **See Series 36-38 literature for more specifications on work sections.**
- **See EFC literature for more specifications and information on EFC.**

MATERIALS:

- **Cast Iron Body**
- **Buna N O'Rings**
- **Heat Treated Steel Spools**

36EFC – GENERAL INFORMATION:

The Brand, 36EFC provides the functionality of Brand’s Series 36-38 stack valve combined with the precise flow control of our EFC valve. This allows users to proportionally control the input flow to the stack valve in one complete package. For example, a motor’s speed on a winch can be controlled in forward and reverse. The 36EFC may also electrically control the rate at which a cylinder extends or retracts. Please refer to EFC, series 36 and series 38 literature for information on work sections, valve capabilities and work section model codes.

WIRING PACKAGES – can be produced to meet any customer’s requirements from simple to complex. Packages can consist of handheld, stationary or a combination of both. They can be for mobile or industrial applications. We can supply packages from coiled cables to special labels and nameplates to give you a true out-of-the-box ready to go package. Please call our engineering department and let us know what your specifications are so that we can design a custom package to suit your needs.

ACCESSORY ITEMS – All tie rod kits contain spacers, tube connector, mounting bracket, rods, foot brackets, lock washers and hex nuts. Please be sure to note that the correct tie rod torque spec is 85 inch lbs. (9.6 N m).

ASSEMBLY MODEL CODES – and list prices for complete assemblies will be issued by the factory upon the request of an authorized Brand Distributor. All model codes that are issued become proprietary to the requesting distributor. Model codes will not be descriptive in nature, but shall be of a sequential numerical type.

36EFC – EXAMPLES OF COMMON MODEL CODES:

- 36EFC12-10**..... 10 gpm (37.8 lpm) flow control, 3-port EFC machined to mount on series 36 inlet (use unloaded inlet).
- 36EFC12-152P**..... 15 gpm (56.7 lpm) flow control, 2-port EFC machined to mount on series 36 inlet (use closed inlet).
- 36PG2CEFC**..... Closed series 36 inlet machined to mount on an EFC (use with 2-port EFC).
- 36PG2UEFC**..... Unloaded series 36 inlet machined to mount on an EFC (use 3-port EFC).

36EFC – CREATING A MODEL CODE FOR 36EFC’S: EFC VALVE:

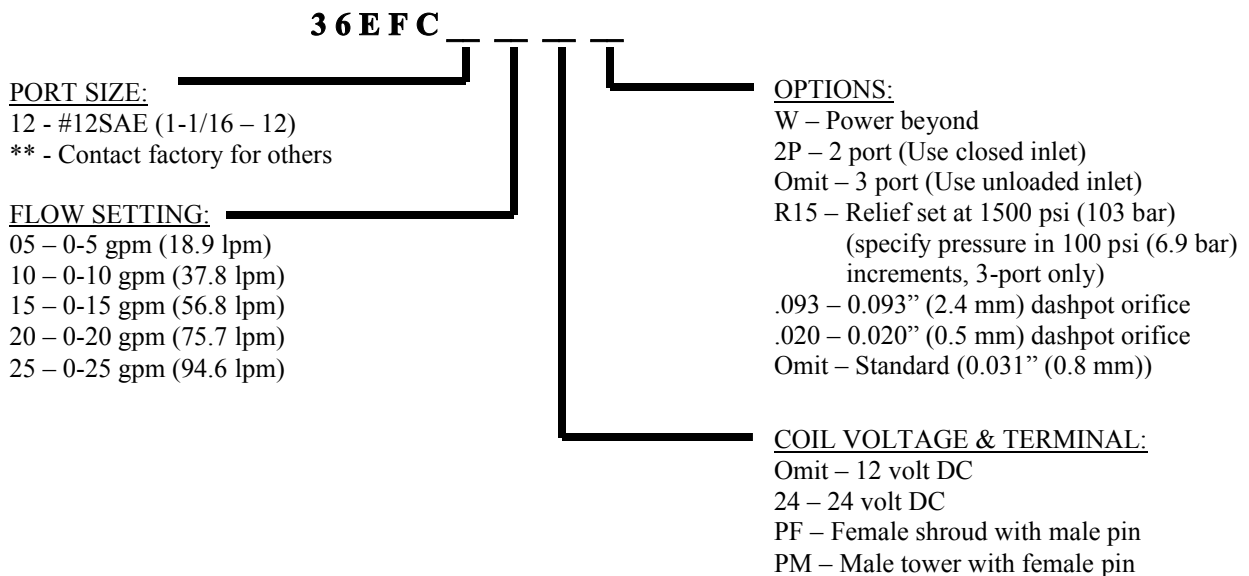

36EFC – CREATING A MODEL CODE FOR 36EFC’S CONT...

36EFC INLET SECTION (USE THIS INLET FOR BOTH SERIES 36 & 38):

3 6 P G 2 _ E F C

CONDITION OF INLET:

- C – Closed inlet (Use with 2-port EFC)
- U – Unloaded inlet (Use with 3-port EFC)
- W – Power beyond (Use with power beyond EFC)

TIE ROD KIT:

3 6 T R _ - E F C

NUMBER OF WORK SECTIONS:

- 1 – One work section
- 2 – Two work sections
- 3 – Three work sections
- ETC...

36EFC – FLOW AND PRESSURE INFO:

Pressure Drop vs. Flow for P to A or B

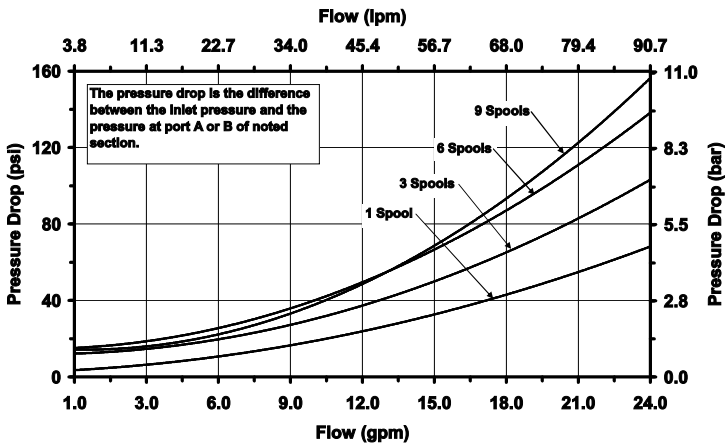

Pressure Drop vs. Flow for A or B to T

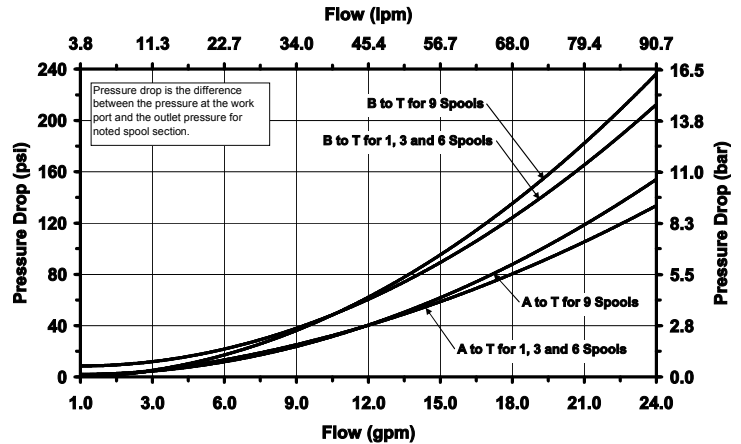

Pressure Drop vs. Flow for EFC Series

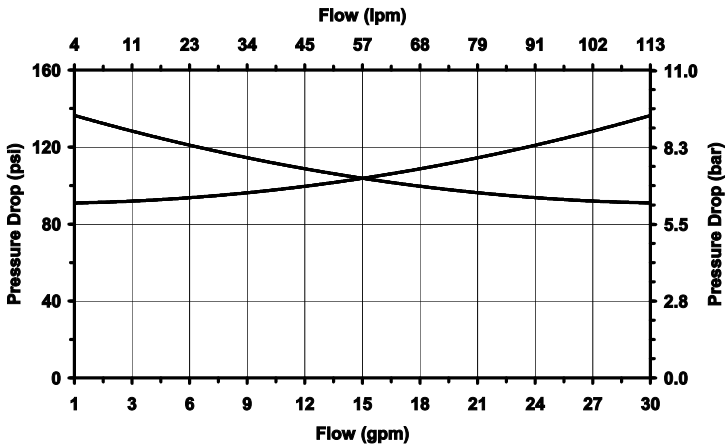

DIMENSIONAL DATA: inches & [millimeters]

